



INFINITY

FR

Principaux avantages

- Système de retenue des condensats
- Facile et rapide à installer
- Fiable et sûre
- Large gamme d'accessoires
- Haut débit
- Tenue au feu: le système ne propage pas de fumée ou de flamme
- Raccords instantanés pour réseaux primaires
- Système totalement métallique

ES

Principales ventajas

- Sistema de separación de condensados
- Fácilidad y rapidez de montaje
- Fiabilidad y seguridad
- Elevado caudal de aire
- Resistencia al fuego: el sistema no alimenta ni propaga el fuego
- Racor automático para la distribución del aire comprimido
- Sistema totalmente metálico

PT

Principais vantagens

- Sistema de separação de condensado
- Facilidade e rapidez de montagem
- Confiabilidade e segurança
- Alta capacidade de vazão de ar
- Gama completa de acessórios
- Resistência as fogo: o sistema não alimenta e não propaga o fogo
- Conexões automáticas para a instalação de redes de ar comprimido
- Sistema totalmente metálico



AIGNEP

Excellent solutions in Fluidtechnology

www.aignep.com



INFINITY LINE

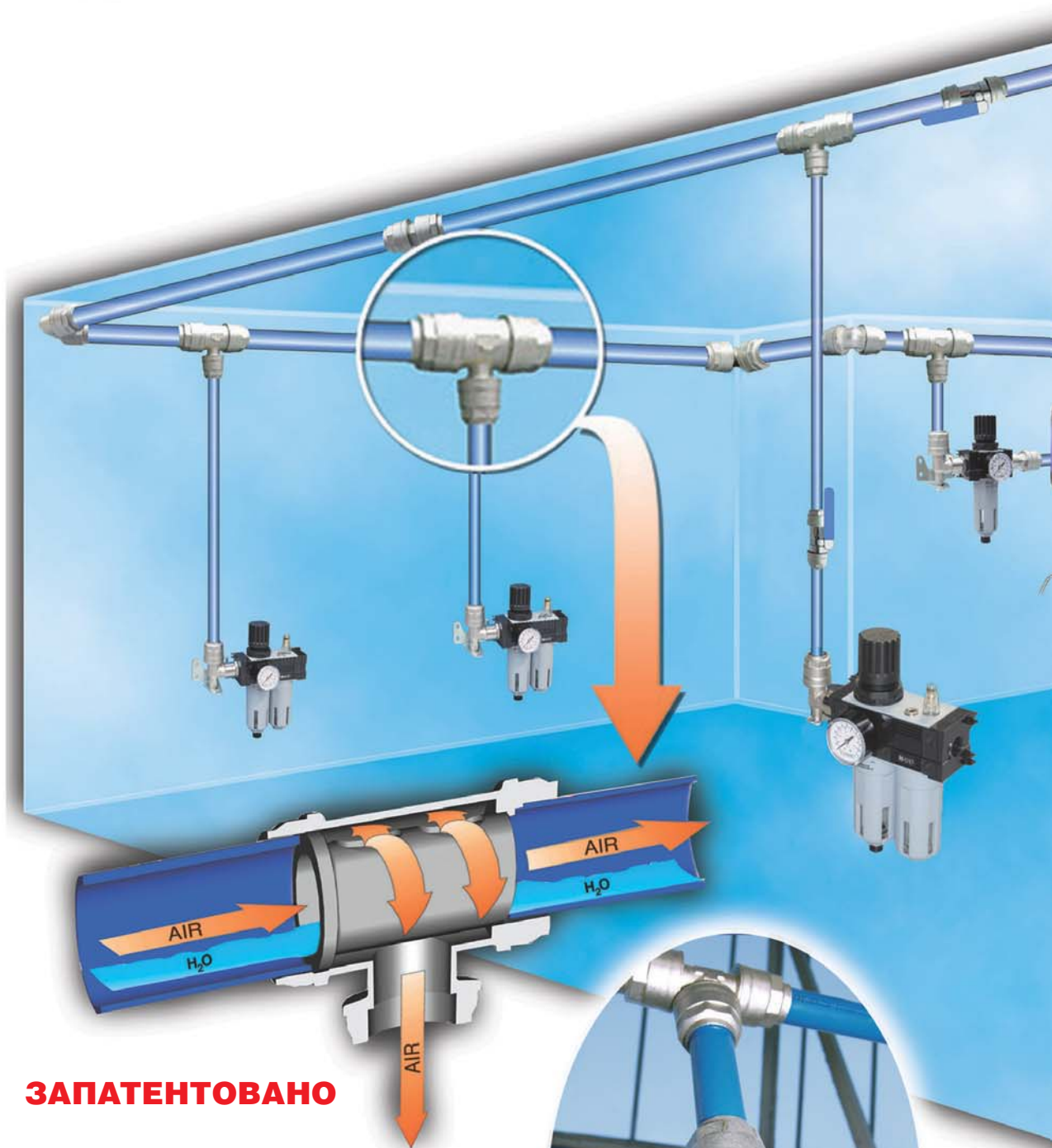

ЗАПАТЕНТОВАНО

ВСТАВЛЯЕМЫЕ НАЖАТИЕМ
ФИТИНГИ ДЛЯ УСТАНОВКИ
ТРУБОПРОВОДОВ ПОДАЧИ
СЖАТОГО ВОЗДУХА

ЛЕГКОСТЬ И БЫСТРОТА СБОРКИ

СИСТЕМА ОТДЕЛЕНИЯ КОНДЕНСАТА

БОЛЬШОЙ АССОРТИМЕНТ
ПРИНАДЛЕЖНОСТЕЙ

НАДЕЖНОСТЬ
И БЕЗОПАСНОСТЬ

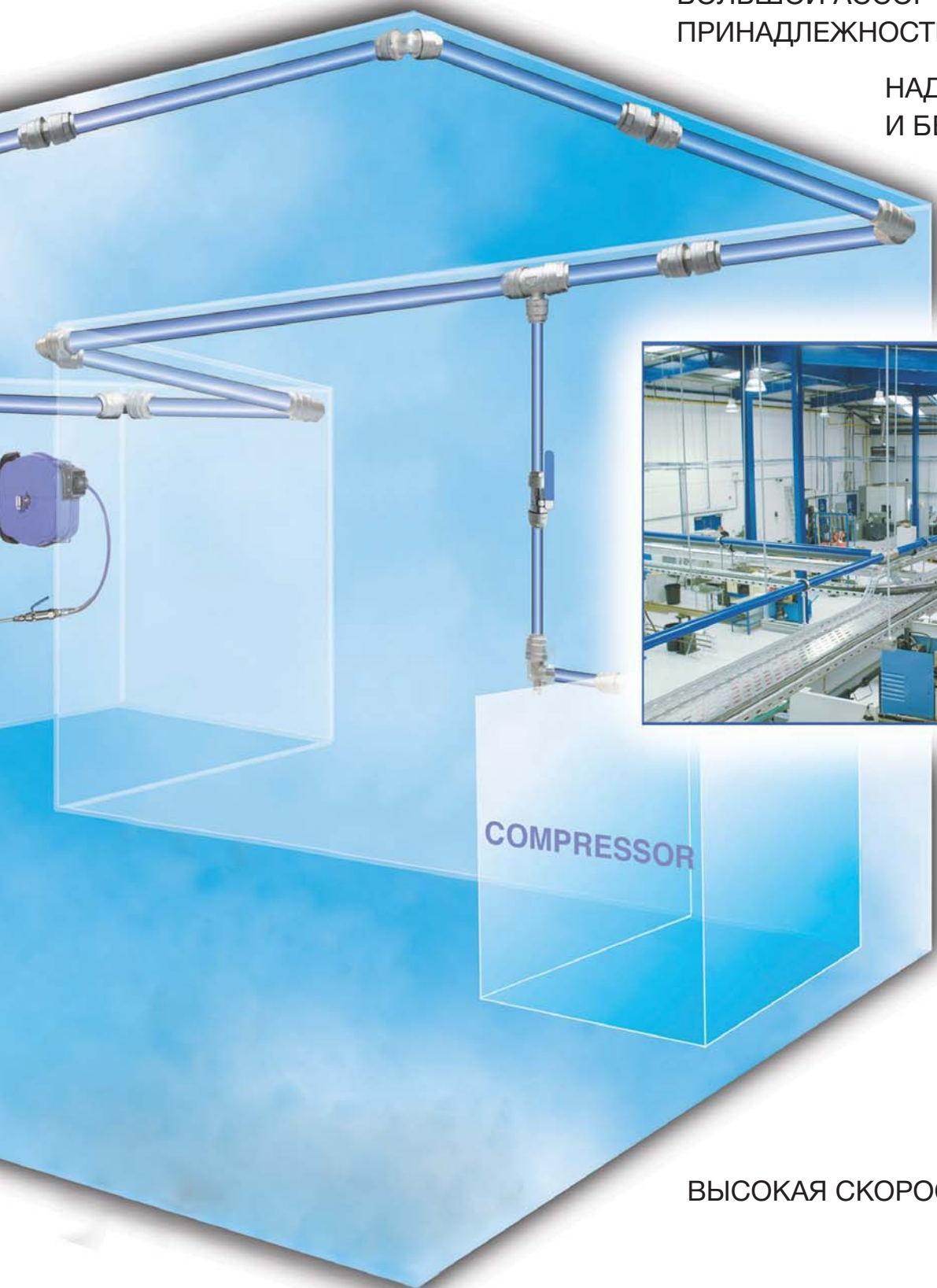

ВЫСОКАЯ СКОРОСТЬ ПОТОКА

ПЕРЕМЕЩЕНИЕ ЭНЕРГИИ СЖАТОГО ВОЗДУХА



Технические характеристики

Ø20 - Ø25 - Ø32 - Ø40 - Ø50 - Ø63

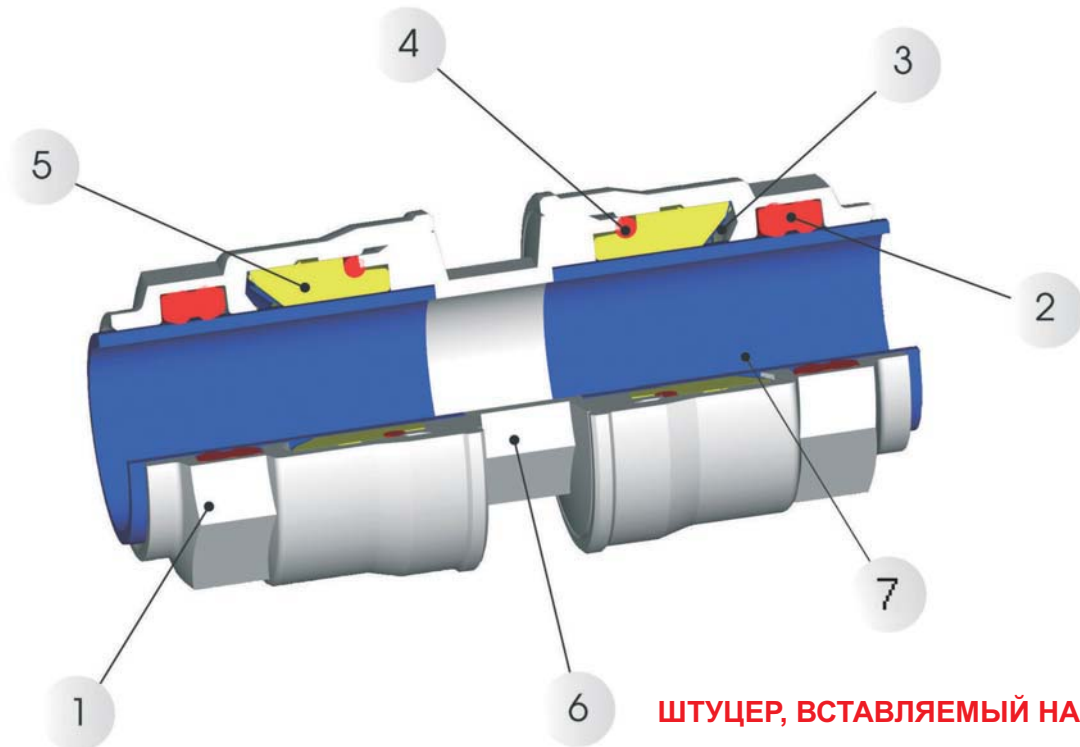

ШТУЦЕР, ВСТАВЛЯЕМЫЙ НАЖАТИЕМ

Комплекующие детали и материалы

1. Гайка латунная никелированная
2. Уплотнение из бутадиен-нитрильного каучука
3. Зажимная шайба из нержавеющей стали AISI 304
4. Уплотнительные кольца из бутадиен-нитрильного каучука
5. Предохранительное кольцо из технополимера
6. Корпус латунный никелированный
7. Труба алюминиевая, изготовленная на прессе непрерывного выдавливания, калиброванная, с порошковой окраской синего цвета (RAL 5010) – серого цвета (RAL 7035).

Давление

Мин. давление -0,99 бар (0,099 МПа)
Макс. давление 16 бар (1,6 МПа)

Совместимые текучие среды

Сжатый воздух
Вакуум
Инертный газ (Азот, Аргон)

Резьба

Фланцевое соединение по стандарту ISO7
Внутренняя резьба по стандарту ISO 228

Температура

Минимальная температура -20°C
Максимальная температура +80°C

Огнестойкость

Система не горит и не передает огонь

Технические характеристики труб

Труба алюминиевая, изготовленная на прессе непрерывного выдавливания
UNI 9006/1 Al Mg 0.5 Si 0.4 Fe 0.2
Обозначения UNI EN 573-3 EN AW 6060 T6
Обработка поверхности Окрашивание в электростатическом поле
Удельный вес 2,70 кг/дм³
Коэффициент расширения 0,024 мм/(м °C)

Ø110

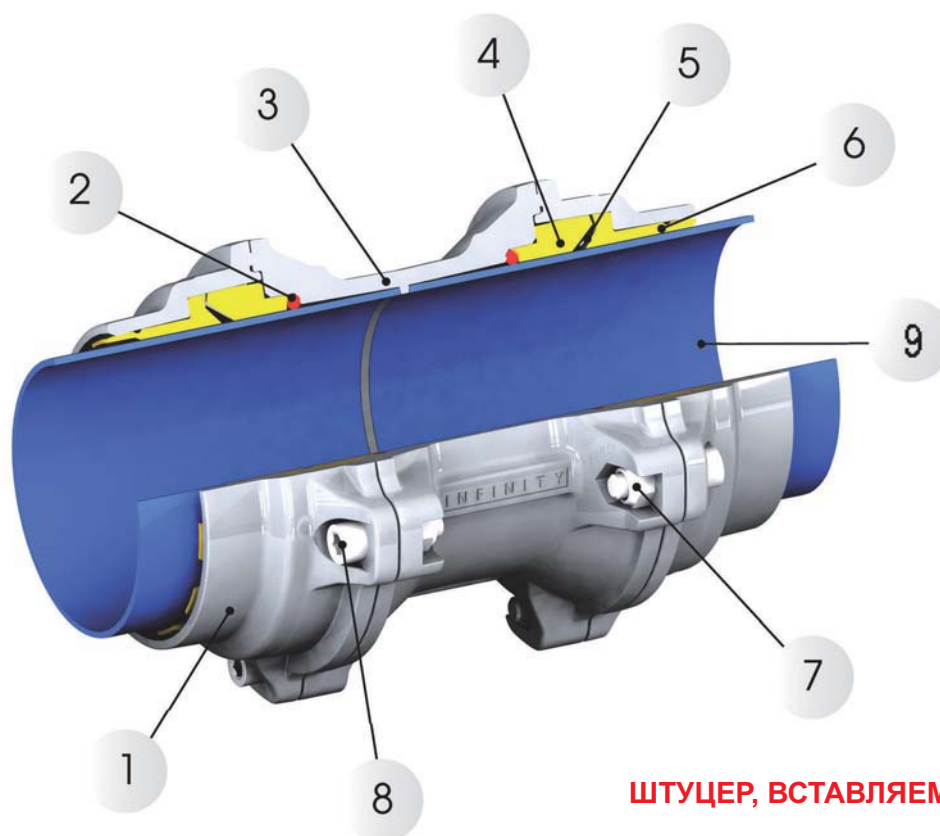

ШТУЦЕР, ВСТАВЛЯЕМЫЙ НАЖАТИЕМ

Комплекующие детали и материалы

1. Гайка алюминиевая с чистовой обработкой поверхности
2. Уплотнительное кольцо из бутадиен-нитрильного каучука
3. Корпус алюминиевый с чистовой обработкой поверхности
4. Предохранительное кольцо из технополимера
5. Зажимная шайба из нержавеющей стали AISI 301
6. Кольцо, направляющее трубу из технополимера
7. Гайка самоконтрящаяся из оцинкованной стали
8. Винт TCEI из оцинкованной стали
9. Труба алюминиевая, изготовленная на прессе непрерывного выдавливания, калиброванная, с порошковой окраской синего цвета (RAL 5010) – серого цвета (RAL 7035).

Давление

Мин. давление -0,99 бар (0,099 МПа)
 Макс. давление 16 бар (1,6 МПа)

Совместимые текучие среды

Сжатый воздух
 Вакуум
 Инертный газ (Азот, Аргон)

Резьба

Фланцевое соединение по стандарту DIN UNI EN 1092 - 4 PN 16
 Внутренняя резьба по стандарту ISO 228

Огнестойкость

Система не горит и не передает огонь

Температура

Минимальная температура -20°C
 Максимальная температура +80°C

Технические характеристики труб

Труба алюминиевая, изготовленная на прессе непрерывного выдавливания
 UNI 9006/1 Al Mg 0.5 Si 0.4 Fe 0.2
 Обозначения UNI EN 573-3
 Обработка поверхности электростатическом поле
 Удельный вес 2,70 кг/дм³
 Коэффициент расширения 0,024 мм/(м °C)

EN AW 6060 T6
 Окрашивание в

Монтаж Ø20 - Ø25 - Ø32 - Ø40

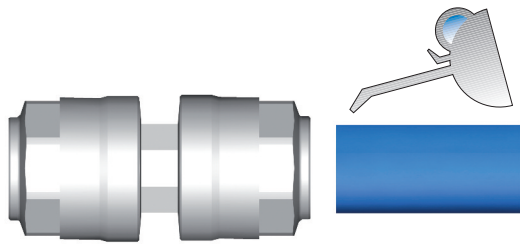

1

1. Фитинги $\varnothing 20 - \varnothing 25 - \varnothing 32 - \varnothing 40$ предварительно собраны. Трубы длиной 4 м и 6 м предварительно окрашены, откалиброваны, заусенцы удалены.

2. Для соединения достаточно вставить трубу в фитинг до упора.

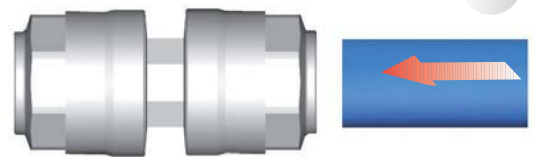

2

3. В случае если фитинг разобран, используйте подходящий инструмент с крутящим моментом, указанным в таблице, чтобы собрать фитинг.

3

Диаметр	Крутящий момент
20	300 сН.м
25	300 сН.м
32	400 сН.м
40	650 сН.м

Монтаж Ø50 - Ø63

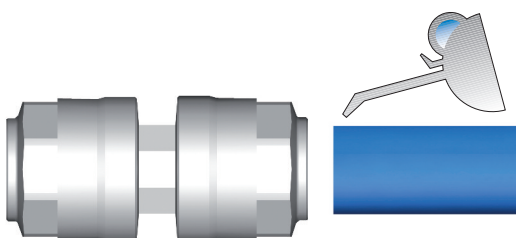

1

1. Фитинги $\varnothing 50 - \varnothing 63$ предварительно собраны, гайка откручена для облегчения соединения с трубой. Трубы длиной 4 м и 6 м предварительно окрашены, откалиброваны, заусенцы удалены.

2. Вставьте трубу в фитинг до упора для соединения и затяните гайку с крутящим моментом, указанным в таблице.

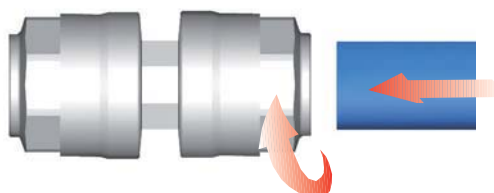

2

Диаметр	Крутящий момент
50	75 Н.м
63	75 Н.м

Монтаж Ø110

1

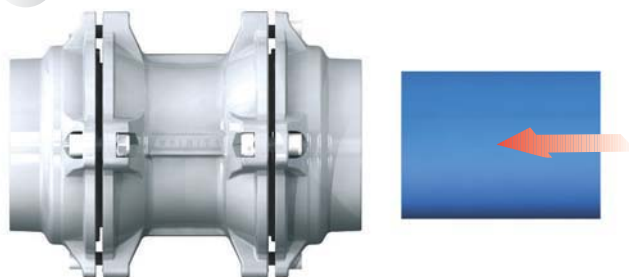

1. Фитинги Ø110 предварительно собраны, четыре винта откручены для облегчения соединения с трубой. Трубы длиной 4 м и 6 м предварительно окрашены, откалиброваны, заусенцы удалены.

2. Вставьте трубу в фитинг до упора для соединения и затяните винты в указанной последовательности с крутящим моментом 30 Нм.

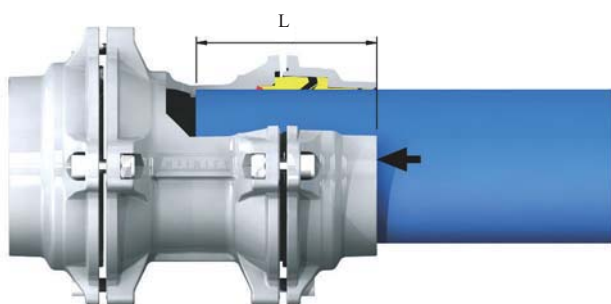

2

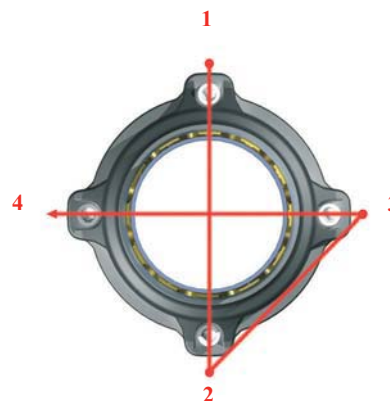

Трубное соединение

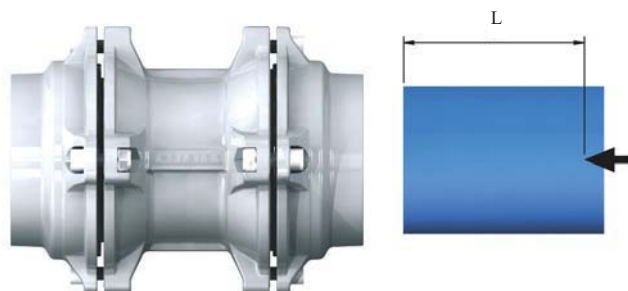
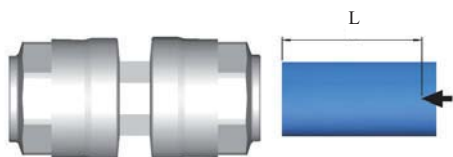

Правильное соединение трубы подтверждается положением нарисованной стрелки. Если необходимо укоротить трубу, отметьте расстояние от края трубы, на которое труба входит в фитинг.

Диаметр	L мм
20	31,5 мм
25	38,5 мм
32	46 мм
40	52 мм
50	63,5 мм
63	75,5 мм
110	125,5 мм

Выберите диаметр для монтажа

Таблица, данная ниже, дает возможность определить диаметр магистрального трубопровода.

1. В красном столбце выберите производительность компрессора.
2. В синем столбце выберите расстояние между компрессором и самым удалённым от него потребителем сжатого воздуха.
3. На пересечении линий производительности и расстояния будет значение оптимального диаметра для магистрального трубопровода.

Производительность			Расстояние между компрессором и самым удалённым от него потребителем										
л/мин	м³/ч	футов³/мин	25 м	50 м	100 м	150 м	200 м	300 м	400 м	500 м	1000 м	1500 м	2000 м
			82 ф	164 ф	328 ф	492 ф	656 ф	984 ф	1312 ф	1640 ф	3280 ф	4921 ф	6562 ф
230	14	8	20	20	20	20	20	20	20	20	20	25	25
650	39	23	20	20	20	20	25	25	25	25	32	32	32
900	54	32	20	20	20	25	25	25	32	32	32	40	40
1200	72	42	20	20	25	25	25	32	32	32	40	40	40
1750	105	62	20	25	25	32	32	32	32	40	40	50	50
2000	120	71	20	25	32	32	32	32	40	40	40	50	50
2500	150	88	25	25	32	32	32	40	40	40	50	50	50
3000	180	106	25	32	32	32	40	40	40	40	50	50	63
3500	210	124	25	32	32	40	40	40	40	50	50	63	63
4500	270	159	32	32	40	40	40	50	50	50	63	63	63
6000	360	212	32	40	40	40	50	50	50	63	63	63	63*
7000	420	247	32	40	40	50	50	50	63	63	63	63*	110
8500	510	300	40	40	50	50	50	63	63	63	63*	110	110
12000	720	424	40	50	50	63	63	63	63	110	110	110	110
15000	900	530	40	50	63	63	63	63	63*	110	110	110	110
18000	1080	636	50	50	63	63	63	110	110	110	110	110	110
21000	1260	742	50	63	63	63	63*	110	110	110	110	110	110*
26000	1560	918	50	63	63	63*	110	110	110	110	110	110*	110*
31000	1860	1095	63	63	63*	110	110	110	110	110	110	110*	110*
33000	1980	1165	63	63	110	110	110	110	110	110	110*	110*	110*
44000	2640	1554	63	63*	110	110	110	110	110	110	110*	110*	110*
50000	3000	1766	63	110	110	110	110	110	110	110	110*	110*	110*
58000	3480	2048	63	110	110	110	110	110	110*	110*	110*	110*	110*
67000	4020	2366	63*	110	110	110	110	110*	110*	110*	110*	110*	110*
75000	4500	2648	110	110	110	110	110	110*	110*	110*	110*	110*	110*
83000	4980	2931	110	110	110	110	110	110*	110*	110*	110*	110*	110*
92000	5520	3249	110	110	110	110*	110*	110*	110*	110*	110*	110*	110*
100000	6000	3531	110	110	110	110*	110*	110*	110*	110*	110*	110*	110*

Давление 7 бар – Общее падение давления 4%

* Падение давления превышает 4%

Пример

Производительность: **1750 л/мин**

Расстояние между компрессором и самым удалённым от него потребителем: **300 м**

Диаметр трубы: **32**

Индикационная производительность компрессоров до 7 бар



кВт	Распределительный клапан	л/мин
1,5	2	230
3	4	460
4	6	650
5,5	7,5	900
7,5	10	1200
11	15	1750
12,5	17	2000
15	20	2500
18	25	3000
22	30	3500
29	40	4500
37	50	6000
45	60	7000
55	75	8500
74	100	12000
92	125	15000
110	150	18000
132	180	21000
170	230	26000
200	270	31000
250	340	44000

Расстояние между компрессором и самым удалённым от него потребителем.

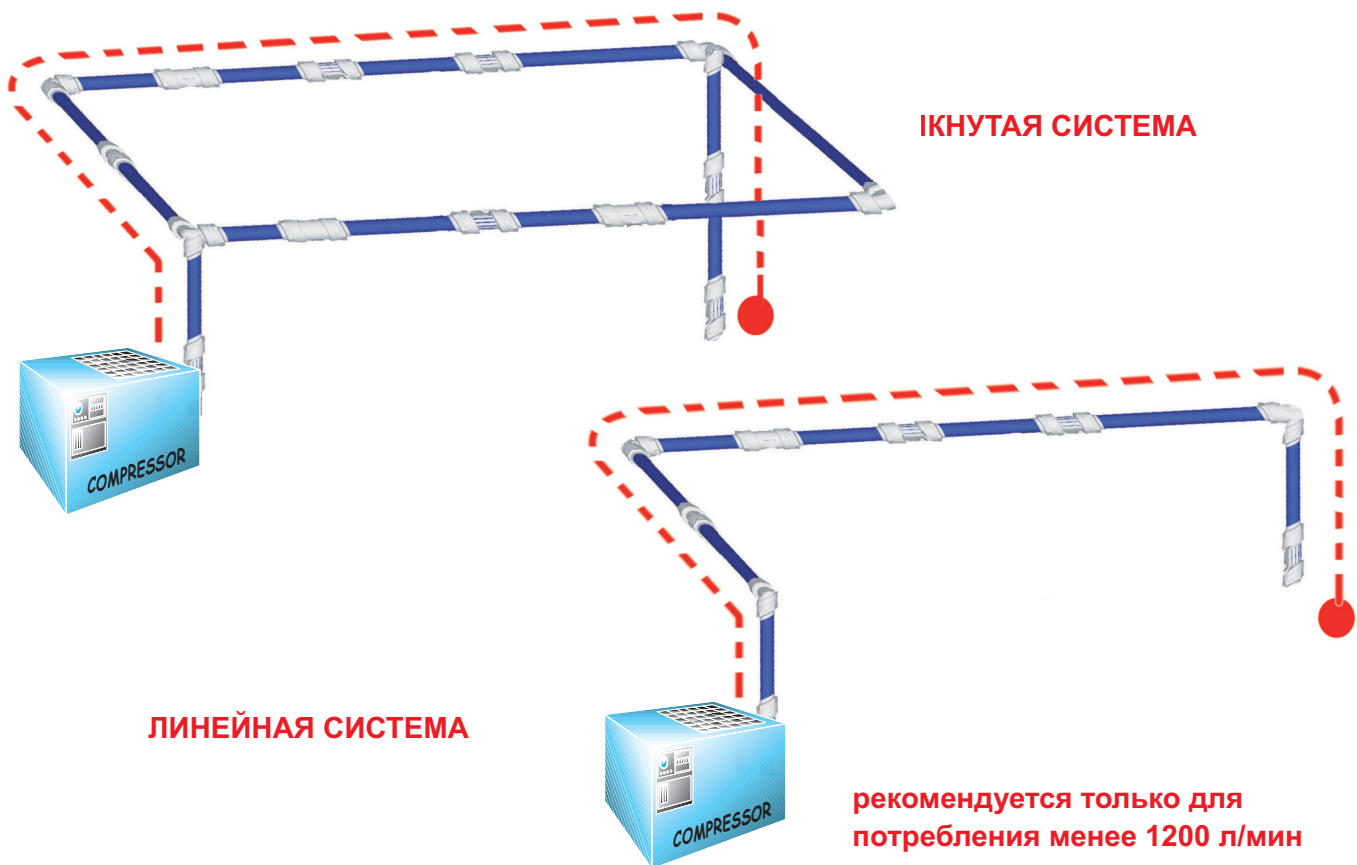

— — — Расстояние между компрессором и самым удалённым от него потребителем.

Диаметр труб для отводов

Спецификации имеющихся в наличии труб для отводов:

- Ø 20 с производительностью до 1750 л/мин
- Ø 25 с производительностью до 3500 л/мин
- Ø 32 с производительностью до 6000 л/мин

Тепловое расширение и сжатие

Для вычисления линейного расширения/сжатия можно использовать следующую формулу:

$$\Delta L = \Delta T \times L \times \alpha \text{ где:}$$

- ΔL = Линейное расширение/сжатие, мм
- ΔT = Разность температур: рабочей температуры и температуры, при которой трубопровод устанавливался, °C
- L = Длина трубы, м
- α = Коэффициент линейного расширения, для алюминия равен 0,024 мм/ м °C

- Установка должна располагаться так, чтобы с двух концов оставалось свободное пространство, обеспечивающее возможность расширения / сжатия, и опоры должны крепиться так, как показано на иллюстрации:

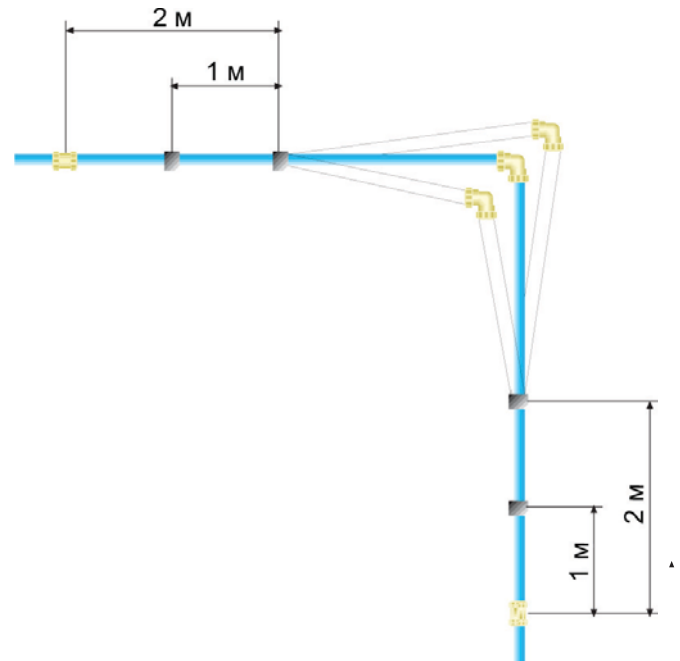

Монтаж Ø20 - Ø25 - Ø32 - Ø40

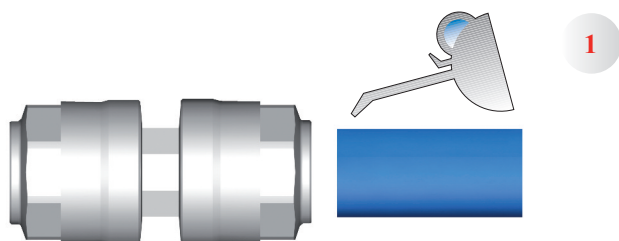

1

1. Фитинги $\varnothing 20 - \varnothing 25 - \varnothing 32 - \varnothing 40$ предварительно собраны. Трубы длиной 4 м и 6 м предварительно окрашены, откалиброваны, заусенцы удалены.

2. Для соединения достаточно вставить трубу в фитинг до упора.



2

3. В случае если фитинг разобран, используйте подходящий инструмент с крутящим моментом, указанным в таблице, чтобы собрать фитинг.

3

Диаметр	Крутящий момент
20	300 сН.м
25	300 сН.м
32	400 сН.м
40	650 сН.м

Монтаж Ø50 - Ø63

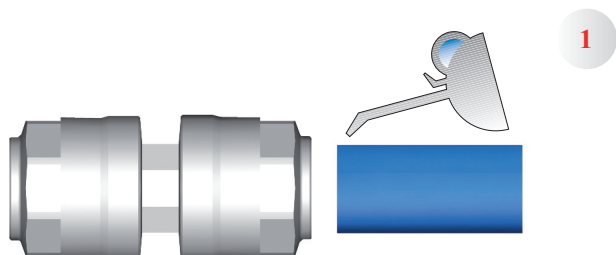

1

1. Фитинги $\varnothing 50 - \varnothing 63$ предварительно собраны, гайка откручена для облегчения соединения с трубой. Трубы длиной 4 м и 6 м предварительно окрашены, откалиброваны, заусенцы удалены.

2. Вставьте трубу в фитинг до упора для соединения и затяните гайку с крутящим моментом, указанным в таблице.

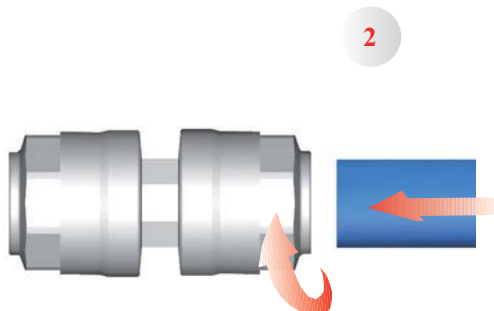

2

Диаметр	Крутящий момент
50	75 Н.м
63	75 Н.м

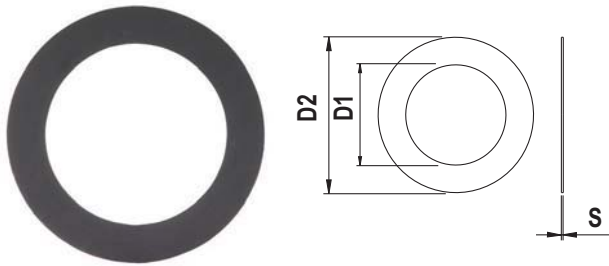

90017-110

ПЛОСКАЯ ПРОКЛАДКА ДЛЯ ФЛАНЦА (ЗАПАСНАЯ ЧАСТЬ)

D	D1	D2	S	Упаковка
110	105	162	2	1



90019-110

ФЛАНЦЕВЫЙ КОМПЛЕКТ

Размер	Упаковка
M16	65 мм 1

КОМПЛЕКТ: 8 ВИНТОВ + 8 ГАЕК + 16 ШАЙБ

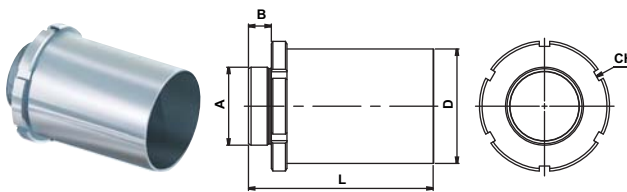

90020-110

УПАКОВКА

D	A	B	L	CH	Упаковка
110	2"-1/2	22	178	*125	1
110	3"	23	179	*125	1

Монтаж 90015

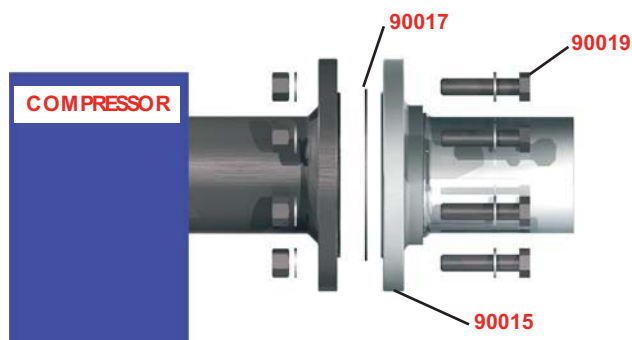

Чтобы соединить систему труб с компрессором, используйте фланцевую трубу арт. 90015

Установите прокладку арт. 90017 между фланцем компрессора и трубой арт. 90015. Затяните восемь винтов арт. 90019. Крутящий момент затяжки 60 Нм.

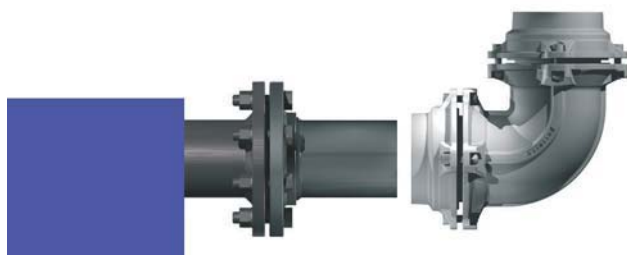

Окончательная сборка показана на рисунке справа.



TUBI IN ALLUMINIO CALIBRATI

 CALIBRATED ALUMINIUM TUBES BLUE COLOUR
 ALUMINIUM ROHR KALIBRIERT
 TUBE ALUMINIUM CALIBRE
 TUBO EN ALUMINIO CALIBRADO
 TUBOS EM ALUMÍNIO CALIBRADOS

90000 - 4 m

color:

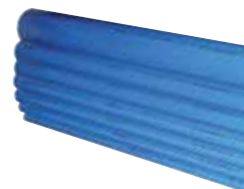
 BLU
 BLUE
 BLAU
 BLEU
 AZUL OSCURO
 AZUL

Code	Ø	Spessore Thickness Dicke Épaisseur Espesor Espessura	Pressioni Pressures Druckbereich Pressions Pressiones Pressões	Peso Weight Gewicht Poids Peso Peso	Lunghezza Lenght Länge Long Longitud Comprimento	Pack.
	mm	mm	bar	g/m	m	
90000 00 11 Y9 B5	20	1.5	16	235	4 m	8
90000 00 11 J4 B5	25	1.5	16	298	4 m	8
90000 00 11 J9 B5	32	1.5	16	387	4 m	9
90000 00 11 K4 B5	40	1.5	16	490	4 m	9
90000 00 11 W0 B5	50	2	16	814	4 m	4
90000 00 11 W3 B5	63	2	16	1034	4 m	4
90000 00 11 TP B5	80	2	16	1283	4 m	2
90000 00 11 HT B5	110	2.5	16	2280	4 m	2

90000 - 4 m

color:

 GRIGIO
 GRAY
 GRAU
 GRIS
 GRIS
 CINZA

Code	Ø	Spessore Thickness Dicke Épaisseur Espesor Espessura	Pressioni Pressures Druckbereich Pressions Pressiones Pressões	Peso Weight Gewicht Poids Peso Peso	Lunghezza Lenght Länge Long Longitud Comprimento	Pack.
	mm	mm	bar	g/m	m	
90000 00 11 Y9 GR	20	1.5	16	235	4 m	8
90000 00 11 J4 GR	25	1.5	16	298	4 m	8
90000 00 11 J9 GR	32	1.5	16	387	4 m	9
90000 00 11 K4 GR	40	1.5	16	490	4 m	9
90000 00 11 W0 GR	50	2	16	814	4 m	4
90000 00 11 W3 GR	63	2	16	1034	4 m	4
90000 00 11 TP GR	80	2	16	1283	4 m	2
90000 00 11 HT GR	110	2.5	16	2280	4 m	2

90000 - 6 m

color:

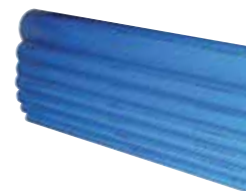
 BLU
 BLUE
 BLAU
 BLEU
 AZUL OSCURO
 AZUL

Code	Ø	Spessore Thickness Dicke Epaisseur Espesor Espessura	Pressioni Pressures Druckbereich Pressions Pressões	Peso Weight Gewicht Poids Peso Peso	Lunghezza Length Länge Long Longitud Comprimento	Pack.
	mm	mm	bar	g/m	m	
90000 6 020 BL	20	1.5	16	235	6 m	8
90000 6 025 BL	25	1.5	16	298	6 m	8
90000 6 032 BL	32	1.5	16	387	6 m	9
90000 6 040 BL	40	1.5	16	490	6 m	4
90000 6 050 BL	50	2	16	814	6 m	4
90000 6 063 BL	63	2	16	1034	6 m	2
90000 6 080 BL	80	2	16	1283	6 m	2
90000 6 110 BL	110	2.5	16	2280	6 m	1

90000 - 6 m

color:

 GRIGIO
 GRAY
 GRAU
 GRIS
 GRIS
 CINZA

Code	Ø	Spessore Thickness Dicke Epaisseur Espesor Espessura	Pressioni Pressures Druckbereich Pressions Pressões	Peso Weight Gewicht Poids Peso Peso	Lunghezza Length Länge Long Longitud Comprimento	Pack.
	mm	mm	bar	g/m	m	
90000 6 020 GR	20	1.5	16	235	6 m	8
90000 6 025 GR	25	1.5	16	298	6 m	8
90000 6 032 GR	32	1.5	16	387	6 m	9
90000 6 040 GR	40	1.5	16	490	6 m	4
90000 6 050 GR	50	2	16	814	6 m	4
90000 6 063 GR	63	2	16	1034	6 m	2
90000 6 080 GR	80	2	16	1283	6 m	2
90000 6 110 GR	110	2.5	16	2280	6 m	1

90000 - 6 m

color:

 VERDE
 GREEN
 GRÜN
 VERT
 VERDE
 VERDE

Code	Ø	Spessore Thickness Dicke Epaisseur Espesor Espessura	Pressioni Pressures Druckbereich Pressions Pressões	Peso Weight Gewicht Poids Peso Peso	Lunghezza Length Länge Long Longitud Comprimento	Pack.
	mm	mm	bar	g/m	m	
90000 6 020 VE	20	1.5	16	235	6 m	8
90000 6 025 VE	25	1.5	16	298	6 m	8
90000 6 032 VE	32	1.5	16	387	6 m	9
90000 6 040 VE	40	1.5	16	490	6 m	4
90000 6 050 VE	50	2	16	814	6 m	4
90000 6 063 VE	63	2	16	1034	6 m	2
90000 6 080 VE	80	2	16	1283	6 m	2
90000 6 110 VE	110	2.5	16	2280	6 m	1

RACCORDI AUTOMATICI PER GLI IMPIANTI DI DISTRIBUZIONE DELL'ARIA

PUSH-IN FITTINGS FOR INSTALLATION OF COMPRESSED-AIR PIPELINES
 STECKVERSCHRAUBUNGEN FÜR DIE INSTALLATION VON DRUCKLUFT-VERTEILSYSTEMEN
 RACCORDS INSTANTANÉS POUR RÉSEAUX PRIMAIRES
 REDES DE AIRE COMPRIMIDO
 CONEXÕES AUTOMÁTICAS PARA A INSTALAÇÃO DE REDES DE AR COMPRIMIDO

90010

RACCORDO DIRITTO MASCHIO

STRAIGHT MALE ADAPTOR
 GERADE EINSCHRAUBVERSCHRAUBUNG
 RACCORD DROIT MÂLE
 RACOR RECTO MACHO
 CONEXÃO RETA COM ROSCA MACHO

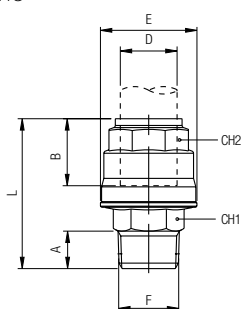

Code	D	F	A	B	E	L	CH1	CH2	Pack.
90010 00 001	20	1/2	14	31.5	34.5	56	22	30	5
90010 00 009	20	3/4	16.5	31.5	34.5	61	22	30	5
90010 00 002	25	3/4	16.5	38.5	42.5	66	27	35	5
90010 00 010	25	1"	19	38.5	42.5	70.5	27	35	5
90010 00 003	32	1"	19	46	52	76.5	34	45	2
90010 00 004	40	1"1/4	21.5	52	63	89.5	45	55	2
90010 00 007	40	1"1/2	21.5	52	63	92	50	55	2
90010 00 005	50	1"1/2	21.5	63.5	73	105	50	65	2
Alluminio - Aluminium - Aluminium - Aluminium - Aluminium - Aluminio									
90010 00 006 A	63	2"	24	57.5	94	109.5	65	75	2
90010 00 008 A	63	2"1/2	24	57.5	94	106.5	75	75	2

90011

NPTF

RACCORDO DIRITTO MASCHIO

STRAIGHT MALE ADAPTOR
 GERADE EINSCHRAUBVERSCHRAUBUNG
 RACCORD DROIT MÂLE
 RACOR RECTO MACHO
 CONEXÃO RETA COM ROSCA MACHO

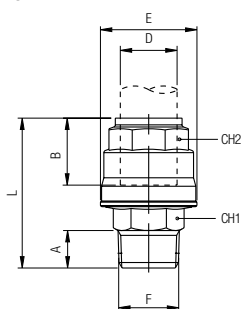

Code	D	F (NPTF)	A	B	E	L	CH1	CH2	Pack.
90011 00 001	20	1/2	14	31.5	34.5	56	22	30	5
90011 00 002	25	3/4	16.5	38.5	42.5	66	27	35	5
90011 00 003	32	1"	19	46	52	76.5	34	45	2
90011 00 004	40	1"1/2	21.5	52	63	89.5	45	55	2
90011 00 005	50	1"1/2	21.5	63.5	73	105	50	65	2
Alluminio - Aluminium - Aluminium - Aluminium - Aluminium - Aluminio									
90011 00 006 A	63	2"	23.5	57.5	94	109.5	65	75	2

90012

RIDUZIONE TUBO-TUBO

TUBE-TUBE REDUCER
 REDUKTION ROHR-ROHR
 RÉDUCTION TUBE-TUBE
 REDUCCIÓN TUBO-TUBO
 REDUÇÃO TUBO-TUBO

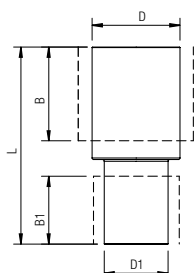

Code	D	D1	B	B1	L	Pack.
90012 00 001	80	63	91	57.5	168	1
90012 00 002	110	80	150.5	91	247	1

90015

TUBO FLANGIATO
 FLANGED TUBE
 FLANSCHANSCHLUSS
 BRIDE CIRCULAIRE
 TUBO BRIDA
 TUBO FLANGEADO

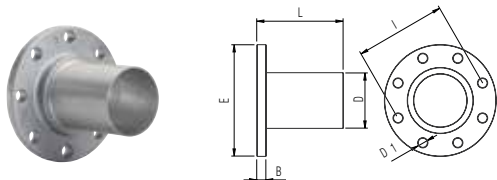

Code	D	B	E	L	D1	I	Pack.
90015 00 002	80	20	200	155	18	160	1
90015 00 001	110	20	220	183	18	180	1

Le dimensioni di accoppiamento della flangia rispettano la norma UNI EN 1092 - 4 PN 16 (Flange in leghe di alluminio).

The connection dimensions of the flange are designed in conformity with standard UNI EN 1092 - 4 PN 16 (Flange made in aluminium alloy).

Die Abmessungen der Flanschverbindung entsprechen der Norm UNI EN 1092 - 4 PN 16 (Flansch aus Aluminiumlegierung).

Les dimensions de raccordement de la bride sont conforme avec la norme UNI EN 1092 - 4 PN 16 (Bride faite en alliage d'aluminium).

Las dimensiones de acoplamiento de la brida, respetan la norma UNI EN 1092 - 4 PN 16 (Brida en aleación de aluminio).

As dimensões de acoplamento da flange respeitam a norma UNI EN 1092 - 4 PN 16 (Flange fabricada em liga de alumínio).

90017

GUARNIZIONE PIATTA PER FLANGIA
 FLAT GASKET FOR FLANGE
 FLACHDICHTUNG FÜR FLANSCH
 JOINT POUR BRIDE CIRCULAIRE
 JUNTA PARA BRIDA (RECAMBIO)
 VEDAÇÃO PLANA PARA FLANGE (REPOSIÇÃO)

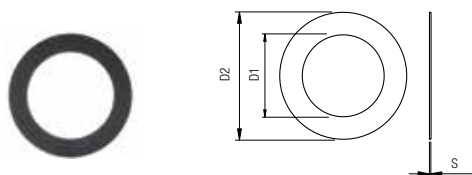

Code	Tube	D1	D2	S	Pack.
90017 00 57 TP 00	80	89	131	2	1
90017 00 57 HT 00	110	115	162	2	1

90018

ANSI 150-LB

TUBO FLANGIATO
 FLANGED TUBE
 FLANSCHANSCHLUSS
 BRIDE CIRCULAIRE
 TUBO BRIDA
 TUBO FLANGEADO

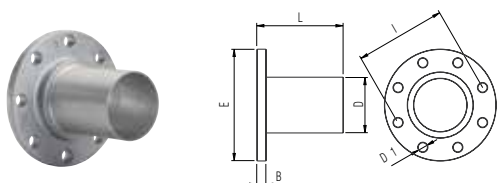

Code	D	B	E	L	D1	I	Pack.
90018 00 007	80	20	190.5	155	19	152.5	1
90018 00 008	110	20	228.5	183.5	19	190.5	1

Le dimensioni di accoppiamento della flangia rispettano la norma ANSI 150-LB (Flange in leghe di alluminio).

The connection dimensions of the flange are designed in conformity with standard ANSI 150-LB (Flange made in aluminium alloy).

Die Abmessungen der Flanschverbindung entsprechen der Norm ANSI 150-LB (Flansch aus Aluminiumlegierung).

Les dimensions de raccordement de la bride sont conforme avec la norme ANSI 150-LB (Bride faite en alliage d'aluminium).

Las dimensiones de acoplamiento de la brida, respetan la norma ANSI 150-LB (Brida en aleación de aluminio).

As dimensões de acoplamento da flange respeitam a norma ANSI 150-LB (Flange fabricada em liga de alumínio).

90019

KIT VITI PER FLANGIA
 FLANGE KIT
 SET SCHRAUBEN FÜR FLANSCH
 KIT BOULON / ECROU POUR BRIDE
 KIT TORNILLOS PARA BRIDA
 KIT DE PARAFUSOS PARA FLANGE



Code	Thread	Size	Pack.
90019 00 001	M16	65 mm	1

KIT: 8 viti + 8 dadi + 16 rondelle

KIT: 8 screw + 8 nut + 16 washer

SET: 8 Schrauben + 8 Muttern + 16 Scheiben

KIT: 8 vis + 8 écrous + 16 rondelles

KIT: 8 tornillos + 8 tuercas + 16 arandelas

KIT: 8 parafusos + 8 porcas + 16 arruelas

Montaggio 90015 - 90018

IT

- 1 Per collegare l'impianto al compressore utilizzare il tubo flangiato art. 90015.
- 2 Porre la guarnizione art. 90017 tra la flangia del compressore e art. 90015. Stringere le otto viti art. 90019. Coppia di serraggio 60 Nm.

Assembling 90015 - 90018

GB

- 1 To connect the pipe system to the compressor use flanged tube art.90015
- 2 Lay flange gasket art. 90017 between compressor flange and art. 90015. Tighten the eight screws art. 90019. Tightening torque 60 Nm.

Montageanleitung 90015 - 90018

DE

- 1 Um das Netz an den Kompressor anzuschliessen, kann der Flanschanschluss Art. 90015 verwendet werden.
- 2 Legen Sie die Flachdichtung Art. 90017 zwischen den Flansch des Kompressors und dem Flanschanschluss Art. 90015. Ziehen Sie die acht Schrauben Art. 90019 mit einem Drehmoment von 60 Nm an.

Assemblage 90015 - 90018

FR

Utilisation de la bride circulaire art. 90015 pour connecter le réseau au compresseur.
Placez le joint art. 90 017 entre la bride du compresseur et la bride circulaire art. 90015. Serrer les huit vis de l'article. 90019 à un couple de serrage de 60 Nm.

Montaje 90015 - 90018

ES

- 1 Para conectar la instalación al compresor utilizar el tubo brida Art. 90015.
- 2 Colocar la junta art. 90017 tras la brida del compresor Art. 90015. Apretar los ocho tornillos Art. 90019. Esfuerzo de torsión 60 Nm.

Montagem 90015 - 90018

PT

- 1 Para conectar o tubo ao compressor utilize o tubo flangeado cód. 90015.
- 2 Coloque a anel de vedação cód. 90017 entre a flange do compressor e o tubo flangeado cód. 90015. Aperte os oito parafusos cód. 90019. Torque de aperto 60 Nm.

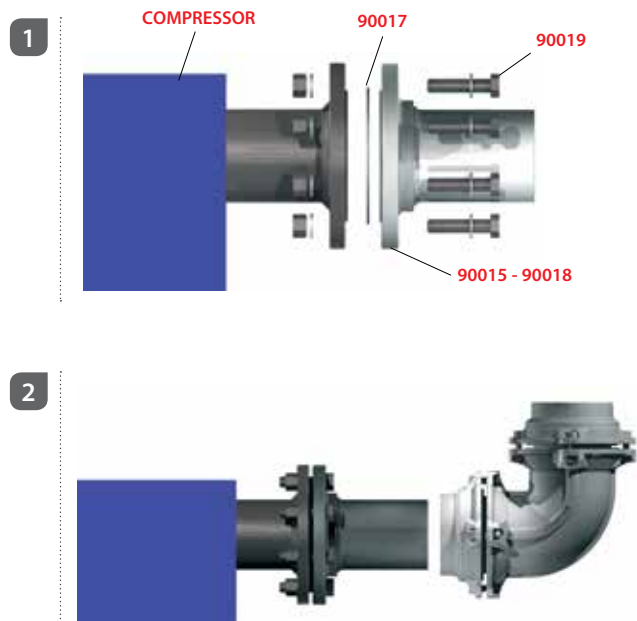

3 A montaggio ultimato si presenta così.
See right-hand side picture for final assembly.
Das Bild zeigt die abgeschlossene Montage.
L'image représente l'assemblage terminé.
El montaje acabado se presenta así.
A montagem final deve ficar com esta aparência.

90020

New

RIDUZIONE TUBO-MASCHIO

TUBE-MALE REDUCER
EINSCHRAUBVERSCHRAUBUNG-ROHR
ADAPTATEUR TUBE-MÂLE
ADAPTADOR TUBO-MACHO
REDUÇÃO TUBO- ROSCA MACHO

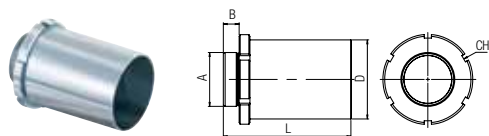

Code	D	A	B	L	CH*	Pack.
90020 00 003	80	2"-1/2	22	143	100	1
90020 00 004	80	3"	23	144	100	1
90020 00 001	110	2"-1/2	22	178	125	1
90020 00 002	110	3"	23	179	125	1
90020 00 005	110	4"	23	179	125	1

*Dimensioni chiave a settore
Hook wrench dimensions
Hakenschlüssel abmessungen
Dimensions de la clé à ergot
Dimensiones llave de gancho
Dimensões para chave tpo gancho

90030

RACCORDO DIRITTO FEMMINA

STRAIGHT FEMALE ADAPTOR
AUFSCHRAUBVERSCHRAUBUNG
RACCORD DROIT, TARAUEE
RACOR RECTO HEMBRA
CONEXÃO RETA COM ROSCA FÊMEA

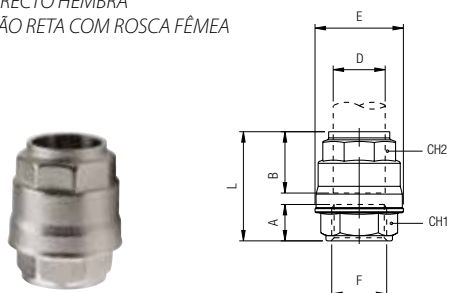

Code	D	F	A	B	E	L	CH1	CH2	Pack.
90030 00 001	20	1/2	15	31.5	34.5	49	24	30	5
90030 00 002	25	3/4	16.5	38.5	42.5	56.5	32	35	5
90030 00 003	32	1"	19	46	52	66.5	38	45	2
90030 00 004	40	1"1/4	22	52	63	76	50	55	2
90030 00 005	50	1"1/2	22	63.5	73	85.5	55	65	2

90040

RACCORDO DIRITTO INTERMEDIO

STRAIGHT CONNECTOR
 VERBINDUNGSVERSCHRAUBUNG
 RACCORD UNION DOUBLE
 RACOR RECTO INTERMEDIO
 CONEXÃO RETA TUBO-TUBO

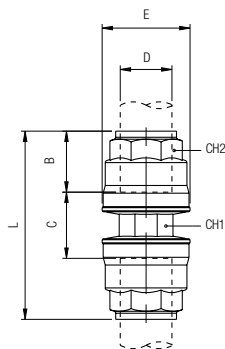

Code	D	B	C	E	L	CH1	CH2	Pack.
90040 00 001	20	31.5	14.5	34.5	76.5	21	30	2
90040 00 002	25	38.5	13.5	42.5	90.5	26	35	2
90040 00 003	32	46	14.5	52	106.5	32	45	2
90040 00 004	40	52	21	63	125	41	55	2
90040 00 005	50	63.5	21.5	73	148.5	50	65	2
Alluminio - Aluminium - Aluminium - Aluminium - Aluminium - Alumínio								
90040 00 006 A	63	57.5	44	94	159	73	75	1

90040 Ø 80-110

RACCORDO DIRITTO INTERMEDIO

STRAIGHT CONNECTOR
 VERBINDUNGSVERSCHRAUBUNG
 RACCORD UNION DOUBLE
 RACOR RECTO INTERMEDIO
 CONEXÃO RETA TUBO-TUBO

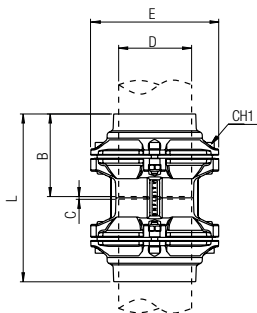

Code	D	B	C	E	L	CH1	Pack.
90040 00 007	80	91	3.5	145	186	6	2
90040 00 008	110	125.5	4	200	255	8	1

90130

RACCORDO A L INTERMEDIO

ELBOW CONNECTOR
 WINKELVERSCHRAUBUNG
 RACCORD EQUERRE
 RACOR A L INTERMEDIO
 CONEXÃO EM "L" TUBO-TUBO

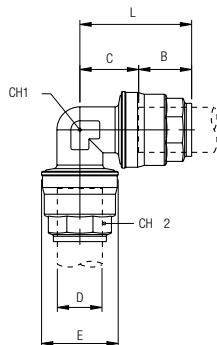

Code	D	B	C	E	L	CH1	CH2	Pack.
90130 00 001	20	31.5	19	34.5	51	21	30	4
90130 00 002	25	38.5	23	42.5	61.5	26	35	4
90130 00 003	32	46	28	52	74.5	34	45	2
90130 00 004	40	52	34	63	86.5	41	55	2
90130 00 005	50	63.5	40.5	73	104	50	65	2
Alluminio - Aluminium - Aluminium - Aluminium - Aluminium - Alumínio								
90130 00 006 A	63	57.5	55.5	94	113	73	75	1

90130 Ø 80-110

RACCORDO A L INTERMEDIO

ELBOW CONNECTOR
WINKELVERSCHRAUBUNG
RACCORD EQUERRE
RACOR A L INTERMEDIO
CONEXÃO EM "L" TUBO-TUBO

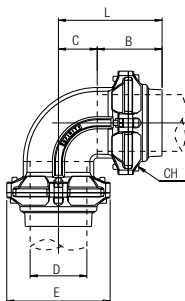

Code	D	B	C	E	L	CH	Pack.
90130 00 007	80	91	54.5	145	146	6	2
90130 000 08	110	125.5	75	200	200.5	8	1

90140

RACCORDO A 135° INTERMEDIO

135° CONNECTOR
WINKELVERSCHRAUBUNG 135°
RACCORD EQUERRE A135°
RACOR INTERMEDIO 135°
CONEXÃO TUBO-TUBO 135°

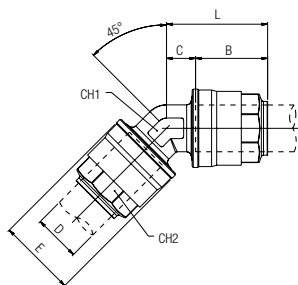

Code	D	B	C	E	L	CH1	CH2	Pack.
90140 00 001	20	31.5	12.5	34.5	44	21	30	4
90140 00 002	25	38.5	13.5	42.5	52	26	35	4
90140 00 003	32	46	15	52	61	34	45	2
90140 00 004	40	52	18	63	70	41	55	2
90140 00 005	50	63.5	20	73	83.5	50	65	2
Alluminio - Aluminium - Aluminium - Aluminium - Aluminium - Aluminium								
90140 00 006 A	63	57.5	24	94	82	73	75	1

90150

RACCORDO A L MASCHIO-TUBO

ELBOW CONNECTOR MALE-TUBE
EINSCHRAUBWINKEL KONISCH
RACCORD FILETÉ MÂLE
RACOR A L MACHO-TUBO
CONEXÃO EM "L" ROSCA MACHO-TUBO

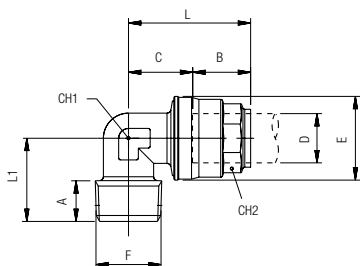

Code	D	F	A	B	C	E	L	L1	CH1	CH2	Pack.
90150 00 001	20	1/2	14	31.5	19	34.5	51	32	21	30	4
90150 00 002	25	3/4	16.5	38.5	23	42.5	61.5	37	26	35	4
90150 00 003	32	1"	19	46	28	52	74.5	49	34	45	2
90150 00 004	40	1"-1/4	21.5	52	34	63	86.5	54	41	55	2
90150 00 005	50	1"-1/2	21.5	63.5	40.5	73	104	59	50	65	2

90160

RACCORDO A L FEMMINA-TUBO

ELBOW CONNECTOR FEMALE-TUBE
 AUFSCHRAUBWINKEL ZYLINDRISCH
 RACCORD FILETÉ FEMELLE
 RACOR A L HEMBRA-TUBO
 CONEXÃO EM "L" ROSCA FÊMEA-TUBO

Code	D	F	A	B	C	E	L	L1	CH1	CH2	Pack.
90160 00 001	20	1/2	13	31.5	19	34.5	51	34.5	21	30	4
90160 00 002	25	3/4	14.5	38.5	23	42.5	61.5	38.5	26	35	4
90160 00 003	32	1"	16.5	46	28	52	74.5	47.5	34	45	2
90160 00 004	40	1"-1/4	20	52	34	63	86.5	56.5	41	55	2
90160 00 005	50	1"-1/2	22	63.5	40.5	73	104	64.7	50	65	2

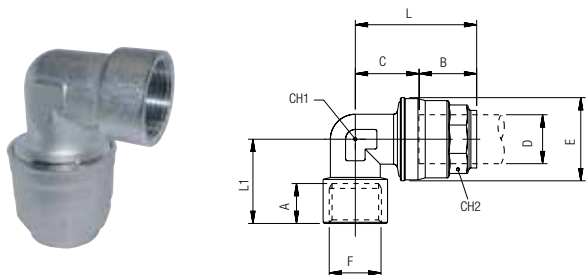

90230

RACCORDO A T INTERMEDIO

TEE CONNECTOR
 T-ANSCHLUSS
 RACCORD TÉ
 RACOR A T INTERMEDIO
 CONEXÃO EM "T" TUBO-TUBO

Code	D	E	B	C1	C2	L1	L2	CH1	CH2	Pack.	
90230 00 001	20	34.5	31.5	34.5	22.5	98	54.5	21	30	3	
90230 00 002	25	42.5	38.5	37.5	26	113.5	65	26	35	3	
90230 00 003	32	52	46	46.5	31.5	138.5	77	34	45	2	
90230 00 004	40	63	52	55.5	38	159.5	90	41	55	1	
90230 00 005	50	73	63.5	69	44.5	196	108	50	65	1	
Alluminio - Aluminium - Aluminium - Aluminium - Aluminium - Aluminio											
90230 00 006 A	63	94	57.5	111	55.5	226	113	73	75	1	

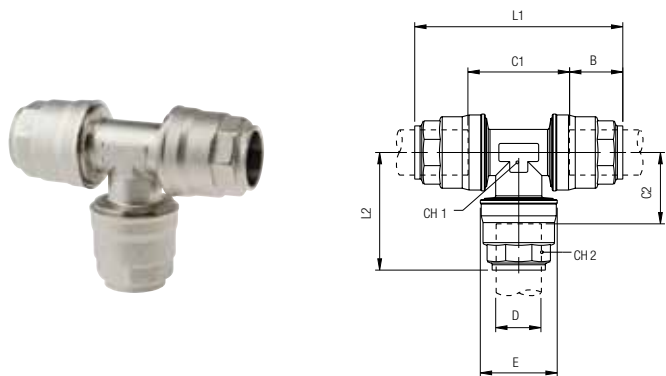

90230 Ø 80-110

RACCORDO A T INTERMEDIO

TEE CONNECTOR
 T-ANSCHLUSS
 RACCORD TÉ
 RACOR A T INTERMEDIO
 CONEXÃO EM "T" TUBO-TUBO

Code	D	E	B	C1	C2	L1	L2	CH	Pack.
90230 00 007	80	145	91	109	54.5	291.5	138	6	1
90230 00 008	110	200	125.5	150.5	75	401	200.5	8	1

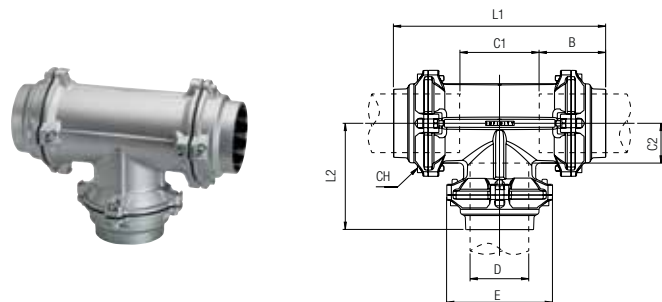

90235

RACCORDO PER CALATA
 FITTING FOR OUTLET
 T-ANSCHLUSS REDUZIERT
 TÈ RÉDUIT
 RACOR A T PARA BAJANTE
 CONEXÃO PARA SAÍDA DE AR

Code	D1	D2	B1	B2	C1	C2	E1	E2	L1	L2	CH	CH1	CH2	Pack.
90235 00 013	20	20	31.5	31.5	48	22.5	34.5	34.5	109	54	28	30	30	3
90235 00 001	25	20	38.5	31.5	45.5	27.5	42.5	34.5	121.5	59	35	35	30	3
90235 00 002	32	20	46	31.5	54.5	31.5	52	34.5	146.5	63	45	45	30	2
90235 00 003	32	25	46	38	54.5	31.5	52	42.5	146.5	70	45	45	35	2
90235 00 004	40	20	52.5	31.5	60	34.5	63	34.5	165.5	66	55	55	30	2
90235 00 005	40	25	52.5	38	60	34.5	63	42.5	165.5	73	55	55	35	2
90235 00 007	50	20	63.5	31.5	73.5	41.5	73	34.5	201	73	65	65	30	1
90235 00 008	50	25	63.5	38.5	73.5	41	73	42.5	201	80	65	65	35	1
90235 00 009	50	32	63.5	46	73.5	41	73	52	201	87.5	65	65	45	1

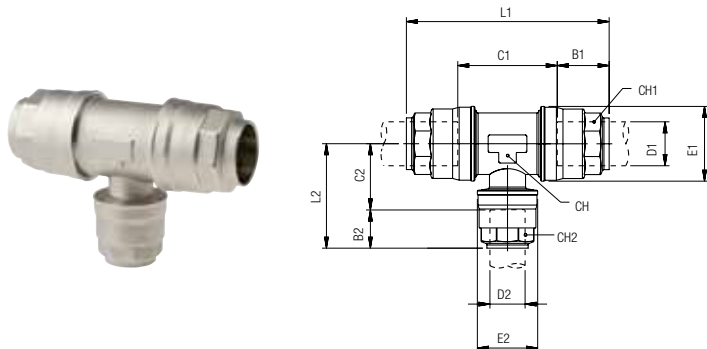

90236

RACCORDO PER CALATA FEMMINA
 FEMALE FITTING FOR OUTLET
 T-ANSCHLUSS MIT INNENGEWINDE
 TÈ FILETÉ
 RACOR PARA BAJANTE ROSCA HEMBRA
 CONEXÃO PARA SAÍDA DE AR (ROSCA FÊMEA)

Code	D	F	A	B	C	E	L	L1	CH	CH1	Pack.
90236 00 006	20	3/8	11	31.5	48	34.5	109	25	28	30	3
90236 00 007	20	1/2	13.5	31.5	48	34.5	109	28	28	30	3
90236 00 001	25	3/8	11	38.5	45.5	42.5	121.5	29	35	35	3
90236 00 008	25	1/2	13.5	38.5	45.5	42.5	121.5	31	35	35	2
90236 00 002	32	1/2	13.5	46	54.5	52	146.5	36.5	45	45	2
90236 00 003	40	1/2	13.5	52.5	60	63	165.5	41.5	55	55	2
90236 00 004	50	3/4	14.5	63.5	73.5	73	201	47.5	65	65	1
Alluminio - Aluminium - Aluminium - Aluminium - Aluminium - Alumínio											
90236 00 017 A	63	1/2	13.5	57.5	88	94	203	53	80	75	1
90236 00 005 A	63	3/4	14.5	57.5	88	94	203	54	80	75	1
90236 00 018 A	63	1"	17.5	57.5	88	94	203	56.5	80	75	1

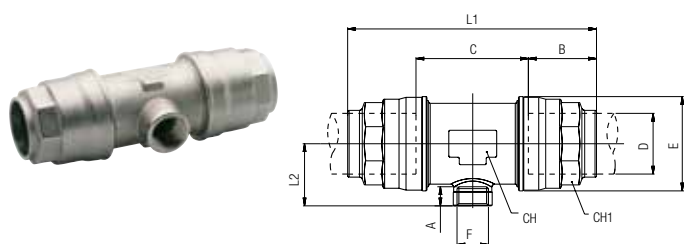

90236 Ø 80-110

RACCORDO PER CALATA FEMMINA
 FEMALE FITTING FOR OUTLET
 T-ANSCHLUSS MIT INNENGEWINDE
 TÈ FILETÉ
 RACOR PARA BAJANTE ROSCA HEMBRA
 CONEXÃO PARA SAÍDA DE AR (ROSCA FÊMEA)

Code	D	F	A	B	C	E	L1	L2	CH	CH1	Pack.
90236 00 009	80	3/4	14.5	91	109	145	291.5	138	6	42	1
90236 00 010	80	1"	17	91	109	145	291.5	138	6	49	1
90236 00 011	80	1"-1/2	20	91	109	145	291.5	138	6	66	1
90236 00 012	80	2"	22	91	109	145	291.5	138	6	80	1
90236 00 013	110	3/4	14.5	125.5	150.5	200	401	180	8	42	1
90236 00 014	110	1"	17	125.5	150.5	200	401	180	8	49	1
90236 00 015	110	1"-1/2	20	125.5	150.5	200	401	180	8	66	1
90236 00 016	110	2"	22	125.5	150.5	200	401	180	8	80	1

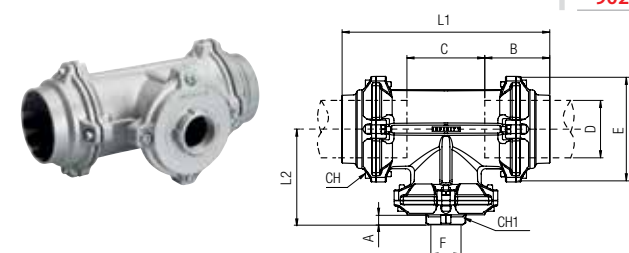

90237

NPTF

RACCORDO PER CALATA FEMMINA

FEMALE FITTING FOR OUTLET
T-ANSCHLUSS MIT INNENGEWINDE
TÉ FILETÉ
RACOR PARA BAJANTE ROSCA HEMBRA
CONEXÃO PARA SAÍDA DE AR (ROSCA FÊMEA)

Code	D	F(NPTF)	A	B	C	E	L	L1	CH	CH1	Pack.
90237 00 007	20	1/2	13.5	31.5	48	34.5	109	25	28	30	3
Alluminio - Aluminium - Aluminium - Aluminium - Aluminio - Alumínio											
90237 00 017 A	63	1/2	13.5	57.5	88	94	203	53	80	75	1
90237 00 005 A	63	3/4	14	57.5	88	94	203	54	80	75	1
90237 00 018 A	63	1"	17	57.5	88	94	203	56.5	80	75	1

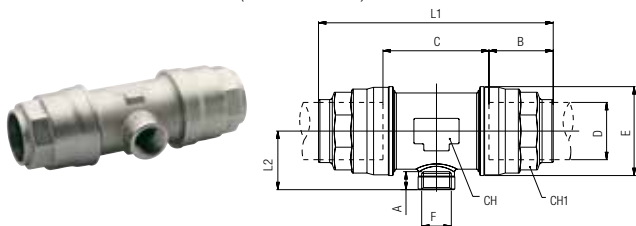

90237 Ø 110

NPTF

RACCORDO PER CALATA FEMMINA

FEMALE FITTING FOR OUTLET
T-ANSCHLUSS MIT INNENGEWINDE
TÉ FILETÉ
RACOR PARA BAJANTE ROSCA HEMBRA
CONEXÃO PARA SAÍDA DE AR (ROSCA FÊMEA)

Code	D	F(NPTF)	A	B	C	E	L	L1	CH	CH1	Pack.
90237 00 013	110	3/4	14	125.5	150.5	200	401	180	8	42	1
90237 00 014	110	1"	17	125.5	150.5	200	401	180	8	49	1
90237 00 015	110	1 1/2"	17.5	125.5	150.5	200	401	180	8	66	1
90237 00 016	110	2"	17.5	125.5	150.5	200	401	180	8	80	1

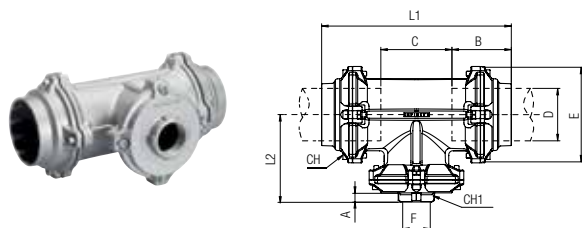

Funzionamento

IT

Questo raccordo è una valida alternativa al tradizionale collo di cigno ma si dimostra una soluzione più rapida ed economica. L'efficace sistema interno permette all'aria, senza ridurre il passaggio, di giungere all'utilizzo priva di condensa che rimanendo nel circuito primario potrà essere così drenata nel punto più conveniente.

Function

GB

This fitting is a valid alternative to the traditional swan-neck; it shows itself as a quicker and cost effective solution. The efficient internal system allows to the air to reach the usage points without any condense which stays within the main circuit and than it can be drained in the most convenient point.

Funktion

DE

Diese Verschraubung ist eine echte Alternative zum traditionellen Schwanenhals, zeigt sich jedoch als eine schnellere und wirtschaftlichere Lösung. Das effizient wirksame interne System erlaubt der Luft zu den Abgängen zu gelangen, ohne jegliches Kondenswasser, welches in der Hauptleitung verbleibt und an der geeigneten Stelle entleert werden kann.

Exécutions

FR

Ce raccord est une alternative au col de cygne traditionnel. Il se monte rapidement et est économique. Le système efficace interne ne réduit pas le passage de l'air et permet la rétention des condensats dans le système principal afin d'être purgé à un endroit propice.

Funcionamiento

ES

Este racor es una alternativa válida al tradicional cuello de cisne, y se demuestra una solución más rápida y económica. El eficaz sistema interno, permite el uso del aire sin ningún tipo de condensados, el cuál permanece en la línea principal y puede ser drenado en el punto más conveniente.

Funcionamento

PT

Esta conexão é uma opção para o tradicional sistema de pescoço de ganso; e apresenta-se como uma solução bem mais rápida e econômica. Este sistema é extremamente eficaz e permite que o ar chegue ao ponto de utilização sem a presença do condensado, que é mantido na tubulação principal de forma a ser drenado em um ponto mais conveniente.

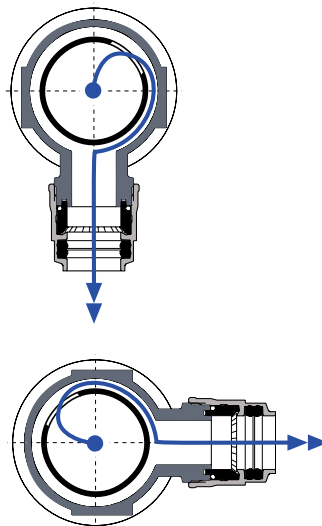
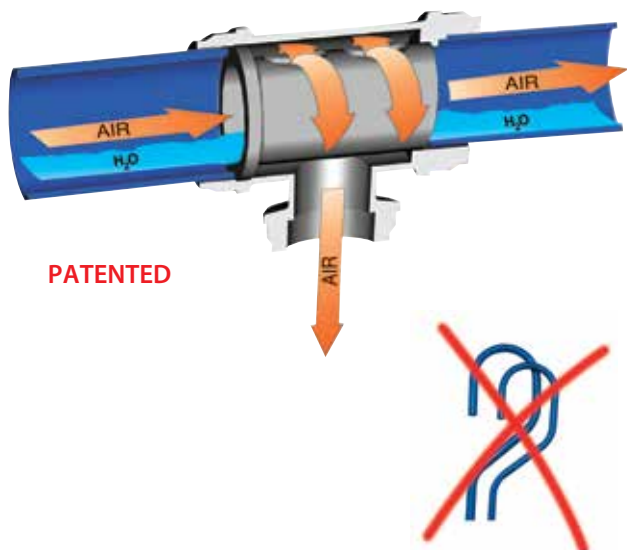

90240

FLANGIA PER CALATA

SADDLE CLAMP CONNECTOR
SCHNELLFLANSCH REDUZIERT
BRIDE DE DÉRIVATION POSE RAPIDE
BRIDA PARA BAJANTE
FLANGE PARA SAÍDA DE AR

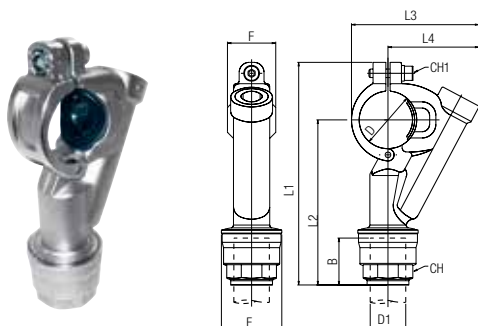

Code	D	D1	B	E	F	L1	L2	L3	L4	CH	CH1	Pack.
90240 00 003	32	20	31.5	34.5	34	136.5	100.5	78	57	30	5	6
90240 00 004	32	25	38.5	42.5	34	144.5	108.5	78	57	35	5	6
90240 00 005	40	20	31.5	34.5	34	148.5	108	89.5	64	30	5	4
90240 00 006	40	25	38.5	42.5	34	156.5	116	89.5	64	35	5	4
90240 00 007	50	20	31.5	34.5	42.5	167.5	118.5	105.5	74	30	6	2
90240 00 008	50	25	38.5	42.5	42.5	175.5	126.5	105.5	74	35	6	1
90240 00 010	63	20	31.5	34.5	42.5	185	130	119	81	30	6	1
90240 00 011	63	25	38.5	42.5	42.5	193	138	119	81	35	6	1

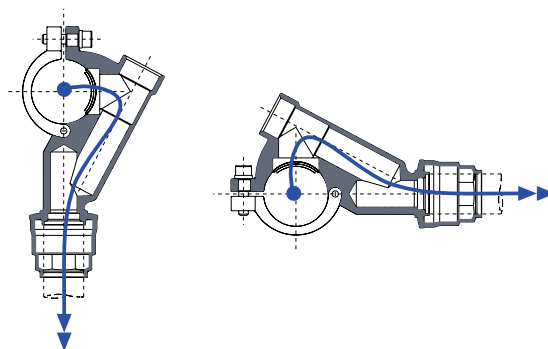

90246

FLANGIA PER CALATA FEMMINA

FEMALE SADDLE CLAMP CONNECTOR
SCHNELLFLANSCH MIT INNENGEWINDE
BRIDE TARAUDÉE
RACOR PARA BAJANTE ROSCA HEMBRA
FLANGE PARA SAÍDA DE AR (ROSCA FÊMEA)

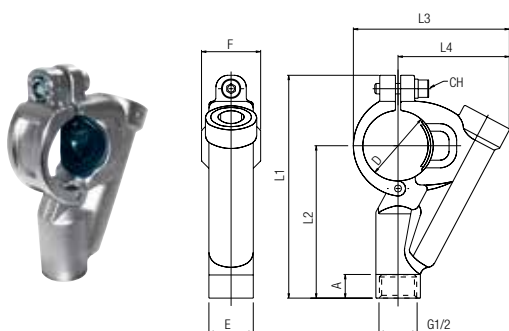

Code	D	A	E	F	L1	L2	L3	L4	CH	Pack.	
90246 00 003	32	1/2	13	25.5	34	115	79	78	57	5	2
90246 00 004	40	1/2	13	25.5	34	125.5	85	89.5	64	5	2
90246 00 005	50	1/2	13	25.5	42.5	144.5	95.5	105.5	74	6	2
90246 00 006	63	1/2	13	25.5	42.5	162	107	119	81	6	1

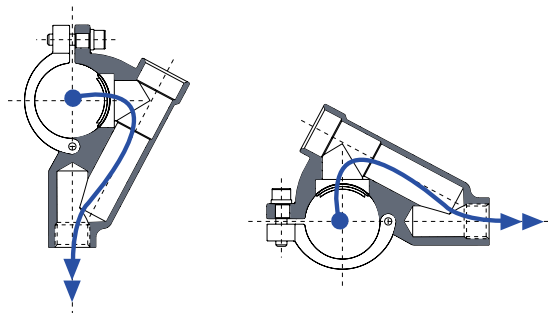

90247

FLANGIA PER CALATA FEMMINA

FEMALE SADDLE CLAMP CONNECTOR
SCHNELLFLANSCH MIT INNENGEWINDE
BRIDE TARAUDÉE
RACOR PARA BAJANTE ROSCA HEMBRA
FLANGE PARA SAÍDA DE AR (ROSCA FÊMEA)

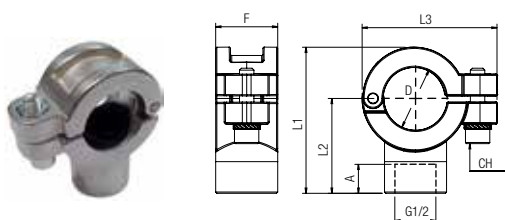

Code	D	A	F	L1	L2	L3	CH	Pack.	
90247 00 002	25	1/2	15	25.5	50	39	55.5	5	2
90247 00 003	32	1/2	15	34	63.5	42.5	61.5	5	2
90247 00 004	40	1/2	15	34	71	46	70	5	2
90247 00 005	50	1/2	15	42.5	83.5	52	84.5	6	2
90247 00 006	63	1/2	15	42.5	95.5	57.5	97	6	1

90247 Ø 80-110

FLANGIA PER CALATA FEMMINA

FEMALE SADDLE CLAMP CONNECTOR

SCHNELLFLANSCH MIT INNENGEWINDE

BRIDE TARAUDÉE

RACOR PARA BAJANTE ROSCA HEMBRA

FLANGE PARA SAÍDA DE AR (ROSCA FÊMEA)

Code	D	B	A	F	L1	L2	L3	CH	Pack.
90247 00 007	80	3/4	16.5	50	117.5	66.5	141.5	6	1
90247 00 008	80	1"	19	50	120	69	141.5	6	1
90247 00 009	110	3/4	16.5	50	152.5	82	189.5	8	1
90247 00 010	110	1"	19	50	155	84.5	189.5	8	1

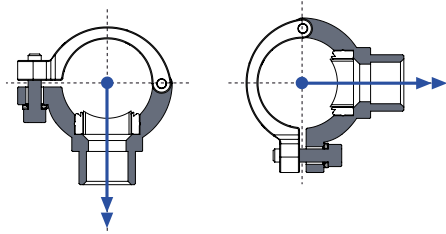
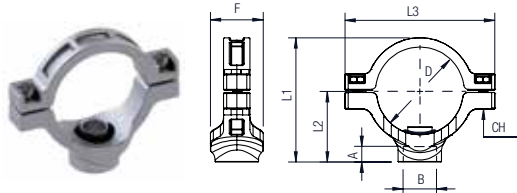

90248

NPTF

FLANGIA PER CALATA FEMMINA

FEMALE SADDLE CLAMP CONNECTOR

SCHNELLFLANSCH MIT INNENGEWINDE

BRIDE TARAUDÉE

RACOR PARA BAJANTE ROSCA HEMBRA

FLANGE PARA SAÍDA DE AR (ROSCA FÊMEA)

Code	D	(NPTF)	A	F	L1	L2	L3	CH	Pack.
90248 00 002	25	1/2	13.5	25.5	50	39	55.5	5	2
90248 00 003	32	1/2	13.5	34	63.5	42.5	61.5	5	2
90248 00 004	40	1/2	13.5	34	71	46	70	5	2
90248 00 005	50	1/2	13.5	42.5	83.5	52	84.5	6	1
90248 00 006	63	1/2	13.5	42.5	95.5	57.5	97	6	1

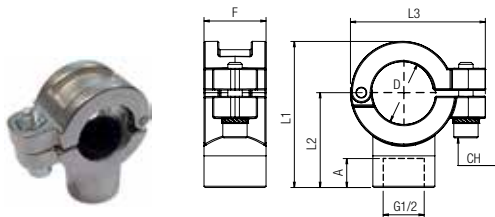

90241

FRESA PER FLANGIA DI CALATA

TOOL FOR SADDLE CLAMP CONNECTOR

BOHRER FÜR SCHNELLFLANSCH

OUTIL DE PERÇAGE

FRESA PARA BRIDA PARA BAJANTE

FRESA PARA PERFURAÇÃO DE TUBOS PARA CRIAÇÃO DE SAÍDA DE AR

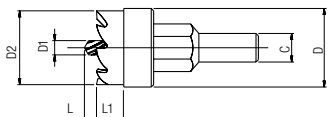

Code	Tube	C	D	D1	D2	L	L1	Pack.
90241 00 003	25	9	17.5	6	17	3	10	1
90241 00 001	32 - 40 - 80 - 110	9	24	6	23.5	3	10	1
90241 00 002	50 - 63	9	31	6	30.5	3	9	1

90242

DIMA PER FORATURA TUBO

DRILLING JIG

BOHRSCHABLONE

GABARIT DE PERÇAGE

ÚTIL PARA TALADRO DEL TUBO

SUPORTE PARA GUIAR FURAÇÃO

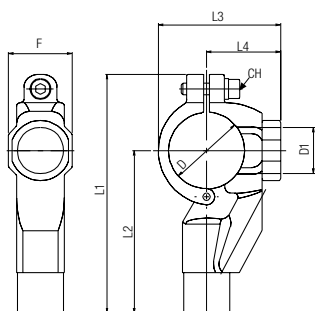

Code	D	D1	F	L1	L2	L3	L4	CH	Pack.
90242 00 001	32	24.5	34	115	79	56	35	5	1
90242 00 002	40	24.5	34	127	86.5	65	39.5	5	1
90242 00 003	50	32	42.5	146	97	79	47.5	6	1
90242 00 004	63	32	42.5	163.5	108.5	93	55	6	1

90249

DIMA PER FORATURA TUBO

DRILLING JIG

BOHRSCHABLONE

GABARIT DE PERÇAGE

BRIDA DE BAJANTE HEMBRA

SUPORTE PARA GUIAR FURAÇÃO

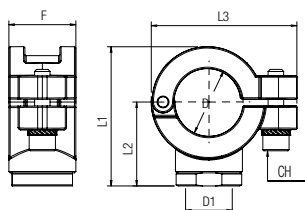

Code	D	D1	F	L1	L2	L3	CH	Pack.
90249 00 002	25	17.8	25.5	53	32	55.5	5	1
90249 00 003	32	24.5	34	56	35	61.5	5	1
90249 00 004	40	24.5	34	65	40	70	5	1
90249 00 005	50	32	42.5	79	47.5	84.5	6	1
90249 00 006	63	32	42.5	93	55	97	6	1

90249 Ø 80-110

DIMA PER FORATURA TUBO

DRILLING JIG

BOHRSCHABLONE

GABARIT DE PERÇAGE

BRIDA DE BAJANTE HEMBRA

SUPORTE PARA GUIAR FURAÇÃO

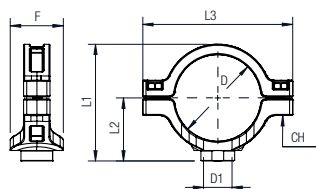

Code	D	D1	F	L1	L2	L3	CH	Pack.
90249 00 007	80	24.5	50	110.5	59.5	141.5	6	1
90249 00 008	110	24.5	50	135.5	64.5	189.5	8	1

Istruzioni montaggio flange

IT

La flangia di calata permette di realizzare una nuova calata in un impianto esistente senza rimuovere tubazioni.

- 1 Depressurizzazione.
- 2 Posizionare art. 90242 sul tubo nel punto desiderato. Accertarsi che il foro di guida sia perpendicolare all'asse di calata. E' possibile inserire un tubo Ø 20 per facilitare il posizionamento della dima.
- 3 Forare il tubo con utensile art. 90241.

Mounting instructions flange

GB

Saddle clamp allows to set up a new drop in an existing system without removing tubes.

- 1 Depressurization.
- 2 Mount art. 90242 on tube wherever necessary. Be careful that jig bore must intersect the axis of tube drop. It is possible to connect a tube diameter Ø 20 to make easier the positioning of the drilling jig.
- 3 Drill the tube with proper tool art. 90241.

Montageanleitung

DE

Die Schnellflansche ermöglichen einen neuen Abgang zu erstellen, ohne dass das Leitungsnetz demontiert werden muss.

- 1 Drucklos.
- 2 Positionieren Sie die Bohrschablone Art. 90242 auf dem Rohr an die gewünschte Stelle. Stellen Sie sicher, dass das Führungsloch senkrecht zur Achse des Abganges ist. Um die Positionierung der Schablone zu erleichtern, legen Sie ein Rohr von Ø20mm Durchmesser ein.
- 3 Bohren des Rohres mit dem Bohrer Art. 90241.

Instructions de montage bride

FR

Les brides permettent d'installer de nouvelles dérivations sur un réseau existant sans démonter les tubes.

- 1 Dépressuriser.
- 2 Placez le gabarit de perçage art. 90242 sur le tube à l'emplacement souhaité. Assurez-vous que le trou de guidage est perpendiculaire à l'axe de descente. Pour faciliter le positionnement du gabarit, insérer un tube de diamètre Ø20 mm.
- 3 Percez le tube avec l'outil art. 90241.

Instrucciones de instalación

ES

La brida para bajante permite realizar un nuevo bajante en una instalación ya terminada sin tener que mover la misma. Para su instalación seguir las siguientes instrucciones.

- 1 Depresurización de la línea.
- 2 Posicionar el art. 90242 centrador sobre el tubo en el punto deseado. El taladro de guía del útil debe ser perpendicular al eje del tubo. Es posible insertar un tubo de Ø20 para facilitar el posicionamiento del tubo.
- 3 Taladrar el tubo con la fresa art. 90241.

Instruções de montagem

PT

A flange para saída de ar permite se criar uma nova saída em uma tubulação existente sem necessidade de remoção dos tubos.

- 1 Depressurização.
- 2 Posicione a peça cód. 90242 no ponto desejado da tubulação. Assure-se que a guia de furação esteja perpendicular ao eixo de saída. Caso deseje, engate um tubo para facilitar o posicionamento da guia.
- 3 Fure o tubo utilizando a fresa cód. 90241

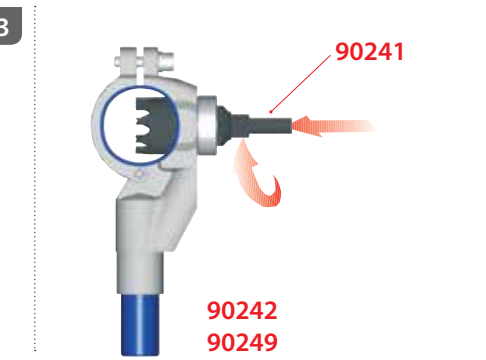
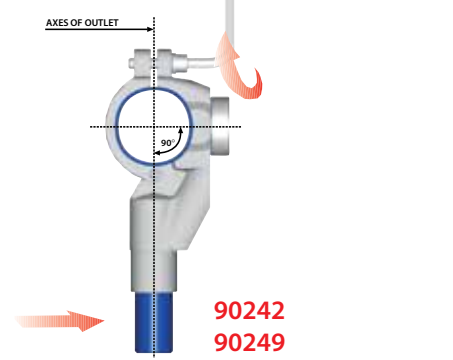

IT

- 4 Fare attenzione a non danneggiare il tubo.
- 5 Smontare art. 90242 e togliere eventuali residui di materiale.
- 6 Montare e avvitare art. 90240. Fate attenzione che la guarnizione a labbro entri correttamente nel foro. Serrate la vite.

GB

- 4 Do not damage the tube.
- 5 Take down art. 90242 and remove residual material
- 6 Mount and tighten art. 90240. Be careful that lipseal lays into the hole correctly. Screw up.

DE

- 4 Beschädigen Sie nicht die andere Seite des Rohres.
- 5 Demontieren Sie die Bohrschablone Art. 90242 und entfernen Späne und entgraten die Bohrung.
- 6 Montieren Sie den Schnellflansch Art. 90240. Stellen Sie sicher, dass die Dichtung richtig positioniert ist und ziehen Sie die Schraube an.

FR

- 4 Ne pas endommager l'autre coté du tube.
- 5 Démontez le gabarit art. 90242, enlever les copeaux et ébavurer.
- 6 Monter la bride art. 90240. Vérifier que le joint est bien positionné et serrer.

ES

- 4 Prestar atención en no dañar la pared opuesta del tubo.
- 5 Desmontar el art. 90242 y eliminar los eventuales residuos de materiales.
- 6 Montar y apretar el art. 90240 de forma que el labio de la junta de estanqueidad se introduzca correctamente en el taladro realizado. Apretar el tornillo para completar el montaje.

PT

- 4 Tenha cuidado para não danificar o outro lado do tubo durante a furação.
- 5 Desmonte a guia cód. 90242 e remova eventuais resíduos presentes na tubulação.
- 6 Monte e parafuse a conexão cód. 90240. Assure-se que a vedação entre corretamente no furo. Aperte o parafuso.

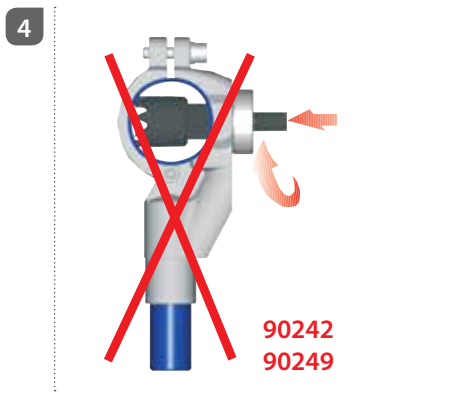

90252

New

STRUMENTO DI FORATURA PER TUBI INFINITY

DRILLING TOOL FOR INFINITY TUBES
BOHRWERKZEUG FÜR INFINITY ROHR
OUTIL PERÇAGE TUBES
HERRAMIENTA DE PERFORACION
FERRAMENTA DE PERFURAÇÃO



Code	Dimensions	Pack.
90252 00 001	25-32-40-50-63	1

90253

New

FLANGIA DI CALATA CON VALVOLA

SADDLE CLAMP CONNECTOR WITH VALVE
SCHNELLFLANSCH MIT INNENGEWINDE U. KUGELHAHN
BRIDE DE DESCENTE AVEC ROBINET
BRIDA PARA BAJANTE HEMBRE CON VALVULA
FLAGE PARA SAIDA DE AR CON ROSCA FEMEA E VÁLVULA DE BÓIA

Code	D	F	L1	L2	L3	CH1	CH2	Pack.	
90253 00 002	25	1/2	25.5	161	97.5	55.5	5	25	1
90253 00 003	32	1/2	34	168	104	61.5	5	25	1
90253 00 004	40	1/2	34	176	112	70	5	25	1
90253 00 005	50	1/2	42.5	188	125	84.5	6	25	1
90253 00 006	63	1/2	42.5	200	137	97	6	25	1

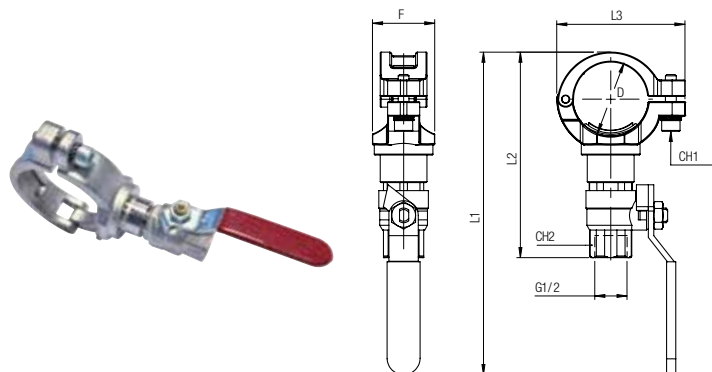

Istruzioni montaggio flangia cod. 90253

IT

- 1 Posizionare la flangia Art. 90253 sul tubo ed avvitare correttamente - aprire la valvola.
- 2 Fissare il Drilling Tool Art. 90252 sulla valvola ed avvitare correttamente.
- 3 Fissare il trapano sul Drilling Tool e forare il tubo fino ad arrivare in battuta.
- 4 Togliere il trapano dal Drilling Tool ed estrarre la punta usata per forare il tubo; chiudere la valvola prima di togliere il Drilling Tool.

Mounting instructions flange 90253

GB

- 1 Mount the saddle clamp Art.90253 on tube and screw it carefully - open the valve.
- 2 Mount the drilling tool Art.90252 on valve and screw it carefully.
- 3 Mount the drill on the drilling tool Art.90252 and drill the tube till the stop.
- 4 Remove the drill and pull back the drill tip; close the valve before removing the drilling tool.

Montageanleitung 90253

DE

- 1 Positionieren Sie den Schnellflansch Art. 90253 auf dem Rohr und ziehen den Flansch an - öffnen Sie den Kugelhahn.
- 2 Befestigen Sie das Bohrwerkzeug Art. 90252 auf dem Kugelhahn und ziehen es richtig an.
- 3 Befestigen Sie die Bohrmaschine auf dem Bohrwerkzeug und bohren bis zum Anschlag in das Rohr.
- 4 Entfernen Sie die Bohrmaschine vom Bohrwerkzeug und schieben den Bohrer ganz zurück; schliessen Sie den Kugelhahn und entfernen das Bohrwerkzeug aus dem Kugelhahn.

Instructions de montage bride code 90253

FR

- 1 Positionner la bride réf. 90253 sur le tube et visser la vis de fixation. Ouvrir la vanne à bille.
- 2 Visser l'outil de perçage réf. 90252 sur la vanne à bille.
- 3 Fixer la perceuse sur l'outil réf. 90252 et percer jusqu'à venir en butée.
- 4 Retirer la perceuse (mèche) et fermer la vanne à bille. Démontez la perceuse puis l'outil de perçage.

Instrucciones de instalación 90253

ES

- 1 Posicionar el art. 90253 sobre el tubo en el punto deseado. Abrir la válvula.
- 2 Montar el art. 90252 en la válvula. Atornille con cuidado.
- 3 Montar la broca sobre el art. 90252 y taladrar el tubo hasta el fondo.
- 4 Retirar la broca. Cierrar la válvula antes que desmontar el art. 90252.

Instruções de montagem 90253

PT

- 1 Montar art. 90253 no tubo. Enroscar cuidadosamente. Abrir a válvula.
- 2 Montar art. 90252 na válvula. Enroscar cuidadosamente.
- 3 Montar a broca de perfuração no art. 90252 e perfurar o tubo até o fim.
- 4 Retirar a broca. Feche a válvula antes de retirar o art. 90252.

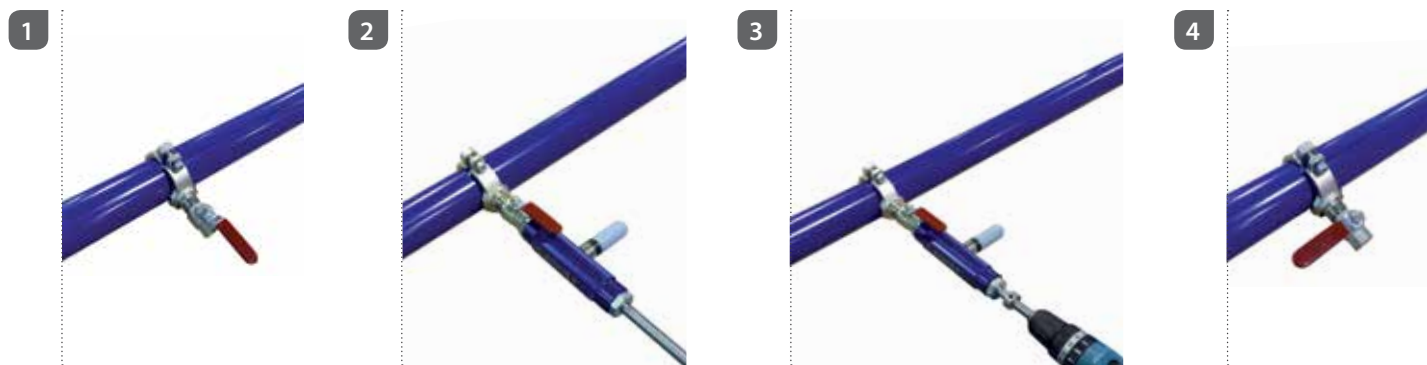

90250

RACCORDO DI SCARICO CONDENZA FEMMINA

FEMALE FITTING WITH CONDENSE EXHAUST INCORPORATED
 ANSCHLUSS MIT INTEGRIERTEM KONDENSATABLASS INNENGEWINDE
 TÊ FEMELLE FILETÉE, SANS RÉTENTION DES CONDENSATS
 RACOR EN T PARA PURGA DE CONDENSADOS HEMBRA
 CONEXÃO PARA DRENAGEM DE CONDENSADO (ROSCA FÊMEA)

Code	D	F	A	B	C	E	L1	L2	CH	CH1	Pack.
Alluminio - Aluminium - Aluminium - Aluminium - Alumínio - Alumínio											
90250 00 017 A	63	1/2	13.5	57.5	88	94	203	53	80	75	1

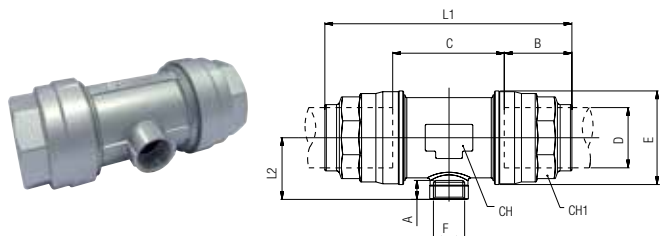

90250 Ø 80-110

RACCORDO DI SCARICO CONDENZA FEMMINA

FEMALE FITTING WITH CONDENSE EXHAUST INCORPORATED
 ANSCHLUSS MIT INTEGRIERTEM KONDENSATABLASS INNENGEWINDE
 TÊ FEMELLE FILETÉE, SANS RÉTENTION DES CONDENSATS
 RACOR EN T PARA PURGA DE CONDENSADOS HEMBRA
 CONEXÃO PARA DRENAGEM DE CONDENSADO (ROSCA FÊMEA)

Code	D	F	A	B	C	E	L1	L2	CH	CH1	Pack.
90250 00 002	80	3/4	14.5	91	109	145	291.5	138	6	42	1
90250 00 001	110	3/4	14.5	125.5	150.5	200	401	180	8	42	1

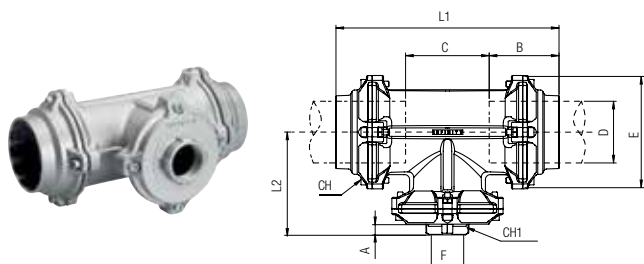

90251

NPTF

RACCORDO DI SCARICO CONDENZA FEMMINA

FEMALE FITTING WITH CONDENSE EXHAUST INCORPORATED
 ANSCHLUSS MIT INTEGRIERTEM KONDENSATABLASS INNENGEWINDE
 TÊ FEMELLE FILETÉE, SANS RÉTENTION DES CONDENSATS
 RACOR EN T PARA PURGA DE CONDENSADOS HEMBRA
 CONEXÃO PARA DRENAGEM DE CONDENSADO (ROSCA FÊMEA)

Code	D	F (NPTF)	A	B	C	E	L1	L2	CH	CH1	Pack.
Alluminio - Aluminium - Aluminium - Aluminium - Alumínio - Alumínio											
90251 00 017 A	63	1/2	13.5	57.5	88	94	203	53	80	75	1

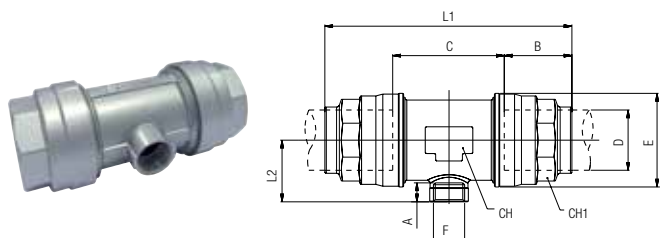

90251 Ø 110

NPTF

Code	D	F (NPTF)	A	B	C	E	L1	L2	CH	CH1	Pack.
90251 00 001	110	3/4	14	91	109	145	291.5	138	6	42	1

RACCORDO DI SCARICO CONDENZA FEMMINA

FEMALE FITTING WITH CONDENSE EXHAUST INCORPORATED
 ANSCHLUSS MIT INTEGRIERTEM KONDENSATABLASS INNENGEWINDE
 TÉ FEMELLE FILETÉE, SANS RÉTENTION DES CONDENSATS
 RACOR EN T PARA PURGA DE CONDENSADOS HEMBRA
 CONEXÃO PARA DRENAGEM DE CONDENSADO (ROSCA FÊMEA)

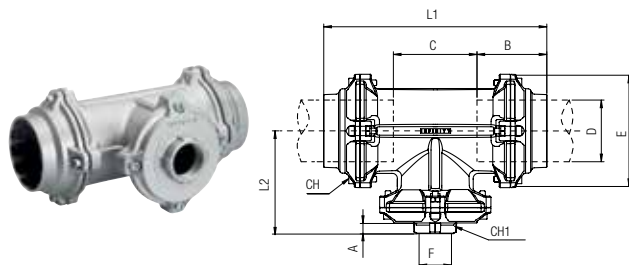

90260

RACCORDO DI SCARICO CONDENZA

FITTING WITH CONDENSE EXHAUST INCORPORATED
 ANSCHLUSS FÜR KONDENSATABLASS
 PURGE DES CONDENSATS
 RACOR CON PURGA DE CONDENSADOS
 CONEXÃO PARA DRENAGEM DE CONDENSADO

Code	D	B	E	L1	L2	CH1	CH2	Pack.
90260 00 001	20	36	34.5	52.5	67	32	30	2
90260 00 002	25	38.5	42.5	57.5	72	32	35	2
90260 00 003	32	46	52	67.5	82	38	45	2
90260 00 004	40	52	63	77	91.5	50	55	2
90260 00 005	50	63.5	73	86.5	101	55	65	1
* 90260 00 006	63	59	92	84	98.5	65	70	1

* Fino ad esaurimento scorta

Until the end stock
 Nur solange vorrat
 Livrable jusqu'à épuisement du stock
 Hasta fin de stock
 Até fim do stock

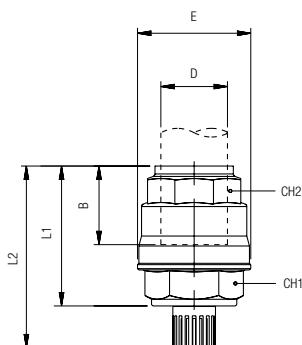

90610

TAPPO
 PLUG
 VERSCHLUSSZAPFEN
 BOUCHON
 TAPÓN
 TAMPÃO

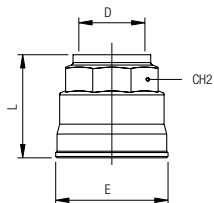

Code	D	L	E	CH2	Pack.
90610 00 001	20	33	34.5	30	10
90610 00 002	25	39	42.5	35	6
90610 00 003	32	46.5	52	45	4
90610 00 004	40	53	63	55	4
90610 00 005	50	62	73	65	2
Alluminio - Aluminium - Aluminium - Aluminium - Aluminium - Alumínio					
90610 00 006 A	63	64	94	75	1

90610 - Ø 80-110

TAPPO
 PLUG
 VERSCHLUSSZAPFEN
 BOUCHON
 TAPÓN
 TAMPÃO

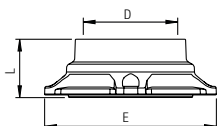

Code	D	L	E	Pack.
90610 00 007	80	49.5	145	1
90610 00 008	110	68	200	1

90620

RIDUZIONE DIRITTA
 REDUCER
 REDUZIERUNG
 RÉDUCTION
 REDUCCIÓN
 REDUÇÃO

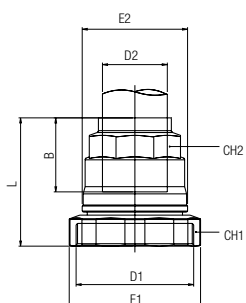

Code	D1	D2	B	E1	E2	L	CH1	CH2	Pack.
90620 00 001	25	20	31.5	43.5	34.5	48	42	30	5
90620 00 002	32	20	31.5	54	34.5	48.5	52	30	5
90620 00 003	32	25	38.5	54	42.5	55	52	35	5
90620 00 004	40	20	31.5	65	34.5	50	63	30	4
90620 00 005	40	25	38.5	65	42.5	56.5	63	35	4
90620 00 006	40	32	46	65	52	63.5	63	45	3
90620 00 011	50	25	38.5	75	42.5	55	73	35	1
90620 00 007	50	32	46	75	52	63.5	73	45	1
90620 00 008	50	40	52	75	63	69	73	55	1
90620 00 009 A	63	40	52	95	63	84.5	92	55	1
90620 00 010 A	63	50	63.5	95	73	92.5	92	65	1

Montaggio 90620

IT

- 1 Rimuovere il dado
- 2 Montare art. 90620

Assembling 90620

GB

- 1 Remove the nut
- 2 Mount art. 90620

Montageanleitung 90620

DE

- 1 Entfernen sie die Mutter
- 2 Montieren art. 90620

Assemblage 90240

FR

- 1 Démontez l'écrou
- 2 Montez art. 90620

Montaje 90620

ES

- 1 Quitar la tuerca
- 2 Montar 90620

Montagem 90620

PT

- 1 Remover a porca
- 2 Montar cód. 90620

1



2



90625

RIDUZIONE FEMMINA

FEMALE REDUCER
 AUFSCHRAUBVERSCHRAUBUNG
 ADAPTATEUR FEMELLE
 ADAPTADOR HEMBRA
 REDUÇÃO COM ROSCA FÊMEA

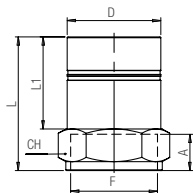

Code	D	F	A	L	L1	CH	Pack.
Alluminio - Aluminium - Aluminium - Aluminium - Aluminio - Aluminio							
90625 00 011 A	63	1"1/2	20	84	62	65	2
90625 00 012 A	63	2"	22	90	62	65	2

90626

NPTF

RIDUZIONE FEMMINA

FEMALE REDUCER
 AUFSCHRAUBVERSCHRAUBUNG
 ADAPTATEUR FEMELLE
 ADAPTADOR HEMBRA
 REDUÇÃO COM ROSCA FÊMEA

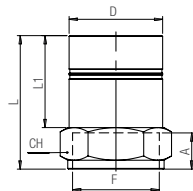

Code	D	F (NPTF)	A	L	L1	CH	Pack.
90626 00 01 CJ NT	20	1/2	13.5	55	35	27	2

90627

RIDUZIONE MASCHIO

MALE REDUCER
 EINSCHRAUBVERSCHRAUBUNG
 ADAPTATEUR MÂLE
 ADAPTADOR MACHO
 REDUÇÃO COM ROSCA MACHO

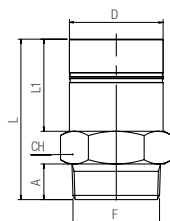

Code	D	F	A	L	L1	CH	Pack.
Alluminio - Aluminium - Aluminium - Aluminium - Aluminio - Aluminio							
90627 00 012 A	63	2"	24	108	62	65	2

90628

NPTF

RIDUZIONE MASCHIO

MALE REDUCER
EINSCHRAUBVERSCHRAUBUNG
ADAPTATEUR MÂLE
ADAPTADOR MACHO
REDUÇÃO COM ROSCA MACHO

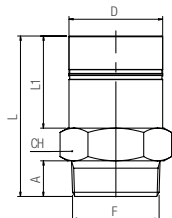

Code	D	F (NPTF)	A	L	L1	CH	Pack.
90628 00 01 CJ NT	20	1/2	17	59	35	22	2
90628 00 01 DH NT	20	3/4	17.5	60.5	35	27	2
90628 00 01 NF NT	25	1/2	17	67	42	27	2
90628 00 01 3I NT	25	3/4	17.5	67.5	42	27	2
90628 00 01 DL NT	25	1"	21.5	73.5	42	34	2
90628 00 01 4I NT	32	1"	21.5	83.5	52	34	1
90628 00 01 F7 NT	32	1"1/2	23	89.5	52	50	1
90628 00 01 NE NT	40	1"1/2	23	93	55.5	50	1
90628 00 01 6I NT	50	1"1/2	23	106	68.5	55	1
90628 00 01 G5 NT	50	2"	23.5	112	68.5	65	1
90628 00 01 7I NT	63	2"	23.5	125.5	82	65	1
90628 00 01 58 NT	63	2"1/2	35	139	82	75	1

90630

RIDUZIONE FEMMINA

FEMALE REDUCER
REDUZIERUNG INNENGEWINDE
RÉDUCTION FILETÉE
REDUCCIÓN HEMBRA
REDUÇÃO FÊMEA

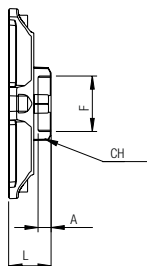

Code	Tube	F	A	L	CH	Pack.
90630 00 005	80	3/4	14.5	42	42	1
90630 00 006	80	1"	17	42	49	1
90630 00 007	80	1"-1/2	20	42	66	1
90630 00 008	80	2"	22	42	80	1
90630 00 001	110	3/4	14.5	48	42	1
90630 00 002	110	1"	17	48	49	1
90630 00 003	110	1"-1/2	20	48	66	1
90630 00 004	110	2"	22	48	80	1

90631

NPTF

RIDUZIONE FEMMINA

FEMALE REDUCER
REDUZIERUNG INNENGEWINDE
RÉDUCTION FILETÉE
REDUCCIÓN HEMBRA
REDUÇÃO FÊMEA

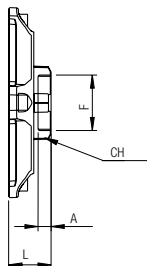

Code	Tube	F (NPTF)	A	L	CH	Pack.
90631 00 005	80	3/4	14	48	42	1
90631 00 006	80	1"	17	48	49	1
90631 00 007	80	1"1/2	17.5	48	66	1
90631 00 008	80	2"	17.5	48	80	1
90631 00 001	110	3/4	14	42	42	1
90631 00 002	110	1"	17	42	49	1
90631 00 003	110	1"1/2	17.5	42	66	1
90631 00 004	110	2"	17.5	42	80	1

90642

RIPARTITORE 2 VIE

2 WAYS MANIFOLD
WANDANSCHLUSS 2-FACH
PRISE MURALE FILETÉE, 2 SORTIES
REPARTIDOR 2 SALIDAS
SAÍDA DE AR DUPLA

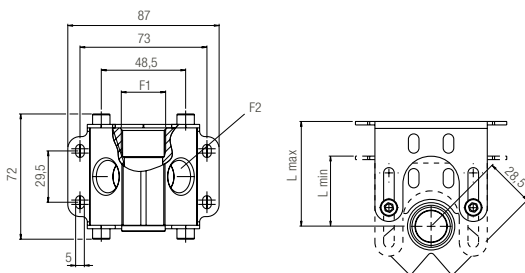

Code	F1	F2	n°	Lmax	Lmin	Pack.
90642 00 001	1/2	1/2	2	60	35	1
90642 00 002	3/4	1/2	2	60	35	1

90643

RIPARTITORE 2 VIE

2 WAYS MANIFOLD
WANDANSCHLUSS 2-FACH
PRISE MURALE FILETÉE, 2 SORTIES
REPARTIDOR 2 SALIDAS
SAÍDA DE AR DUPLA

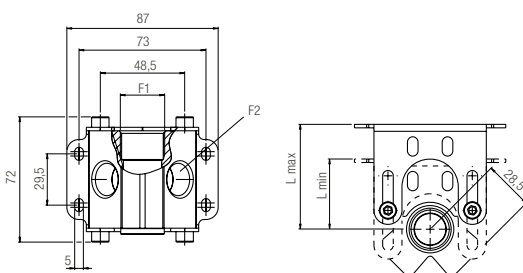

NPTF

Code	F1 (NPTF)	F2 (NPTF)	n°	Lmax	Lmin	Pack.
90643 00 001	1/2	1/2	2	60	35	1
90643 00 002	3/4	1/2	2	60	35	1

ESEMPI DI APPLICAZIONI - APPLICATIONS EXAMPLE - BEISPIELE FÜR ANWENDUNGEN
EXEMPLES D'APPLICATIONS - EJEMPLO DE APLICACIÓN - EXEMPLOS DE APLICAÇÕES

90642
90010
661



90642
90720
661



90642
90010
6310
661



90642
90720
6310
661



90642
90010
6310
191



90642
90720
6310
191



90642
90010
191



90642
90720
191



90642
90010
2060
T100
661



90644

RIPARTITORE 4 VIE

4 WAYS MANIFOLD
WANDANSCHLUSS 4-FACH
PRISE MURALE FILETÉE, 4 SORTIES
REPARTIDOR 4 SALIDAS
SAÍDA DE AR QUADRUPLA

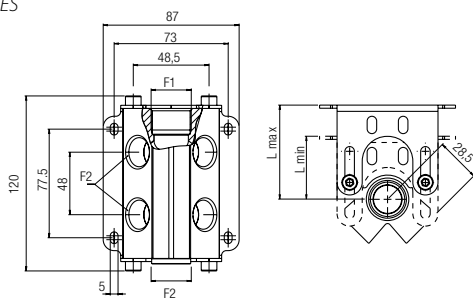

Code	F1	F2	n°	Lmax	Lmin	Pack.
90644 00 001	1/2	1/2	4	60	35	1
90644 00 002	3/4	1/2	4	60	35	1

90645

RIPARTITORE 4 VIE

4 WAYS MANIFOLD
WANDANSCHLUSS 4-FACH
PRISE MURALE FILETÉE, 4 SORTIES
REPARTIDOR 4 SALIDAS
SAÍDA DE AR QUADRUPLA

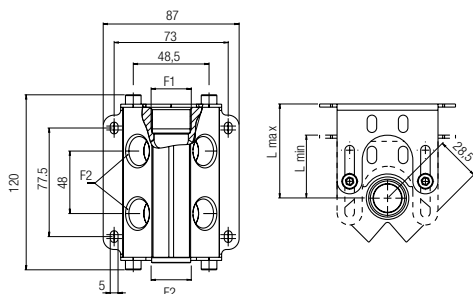

NPTF

Code	F1 (NPTF)	F2 (NPTF)	n°	Lmax	Lmin	Pack.
90645 00 001	1/2	1/2	4	60	35	1
90645 00 002	3/4	1/2	4	60	35	1

ESEMPLI DI APPLICAZIONI - APPLICATIONS EXAMPLE - BEISPIELE FÜR ANWENDUNGEN
EXEMPLES D'APPLICATIONS - EJEMPLO DE APLICACIÓN - EXEMPLOS DE APLICAÇÕES

90644
90010
661



90644
90720
661



90644
90010
6310
661



90644
90010
6310
661



90644
90010
6310
661



90644
90720
191



90644
90010
6310
191



90644
90720
6310
191



90644
90010
2060
T100
661



90600

RACCORDO A STAFFA - ORIENTABILE

BRACKET FITTING - ADJUSTABLE
 WANDANSCHLUSS 1-FACH - EINSTELLBAR
 PRISE MURALE, 1 SORTIE FEMELLE - ORIENTABLE
 RACOR CODO A FIJACIÓN 1 SALIDA
 SAÍDA DE AR DUPLA - ORIENTÁVEL

Code	D	F	B	C	E	L1	L2	L3	Lmax	Lmin	CH1	CH2	Pack.
90600 00 001	20	1/2	31.5	19.5	34.5	35	51	35	40	22	21	30	4
90600 00 002	25	3/4	38.5	23	42.5	37	62	39	40	22	26	35	3
90600 00 003	32	1"	46	28	52	41	74.5	48.5	40	26	34	45	2

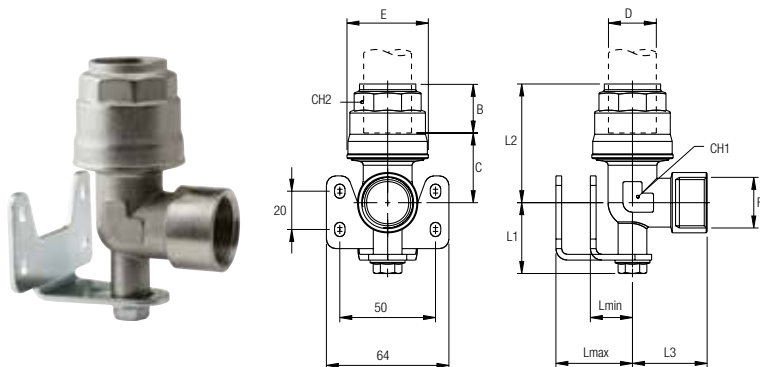

90601

NPTF

RACCORDO A STAFFA - ORIENTABILE

BRACKET FITTING - ADJUSTABLE
 WANDANSCHLUSS 1-FACH - EINSTELLBAR
 PRISE MURALE, 1 SORTIE FEMELLE - ORIENTABLE
 RACOR CODO A FIJACIÓN 1 SALIDA
 SAÍDA DE AR DUPLA - ORIENTÁVEL

Code	D	F (NPTF)	B	C	E	L1	L2	L3	Lmax	Lmin	CH1	CH2	Pack.
90601 00 001	20	1/2	31.5	19.5	34.5	35	51	35	40	22	21	30	4
90601 00 002	25	1/2	38.5	23	42.5	37	62	39	40	22	26	35	3
90601 00 003	32	1/2	46	28	62	41	74.5	48.5	40	26	34	45	2

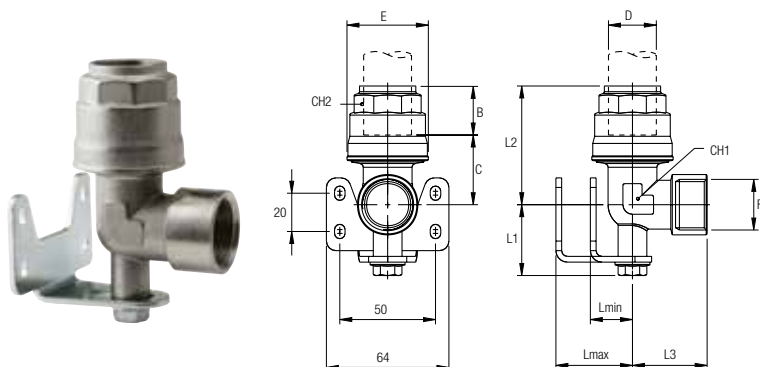

90602

RIPARTITORE 2 VIE ORIENTABILE

2 WAYS MANIFOLD - ADJUSTABLE
 WANDANSCHLUSS 2-FACH - EINSTELLBAR
 PRISE MURALE, 2 SORTIES FEMELLES - ORIENTABLE
 REPARTIDOR 2 SALIDAS AJUSTABLE
 SAÍDA DE AR DUPLA - ORIENTÁVEL

Code	D	F	B	C	E	I	L1	L2	Lmin	Lmax	CH1	CH2	Pack.
90602 00 001	20	1/2	31.5	20	34.5	28.5	27	51.5	22	54	26	30	2
90602 00 002	25	1/2	38.5	21	42.5	28.5	27	59	22	54	26	35	2

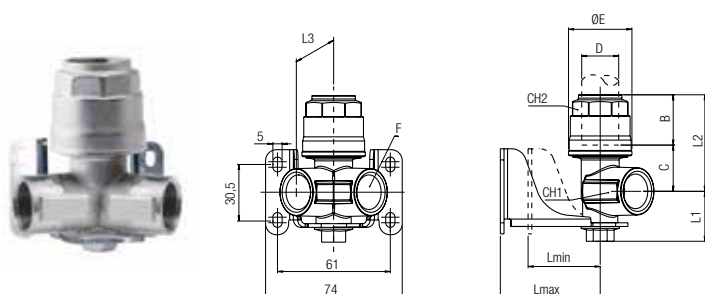

90603

NPTF

RIPARTITORE 2 VIE ORIENTABILE

2 WAYS MANIFOLD - ADJUSTABLE
 WANDANSCHLUSS 2-FACH - EINSTELLBAR
 PRISE MURALE, 2 SORTIES FEMELLES - ORIENTABLE
 REPARTIDOR 2 SALIDAS AJUSTABLE
 SAÍDA DE AR DUPLA - ORIENTÁVEL

Code	D	F (NPTF)	B	C	E	I	L1	L2	Lmin	Lmax	CH1	CH2	Pack.
90603 00 001	20	1/2	31.5	20	34.5	28.5	27	51.5	22	54	26	30	2
90603 00 002	25	1/2	38.5	21	42.5	28.5	27	59	22	54	26	35	2

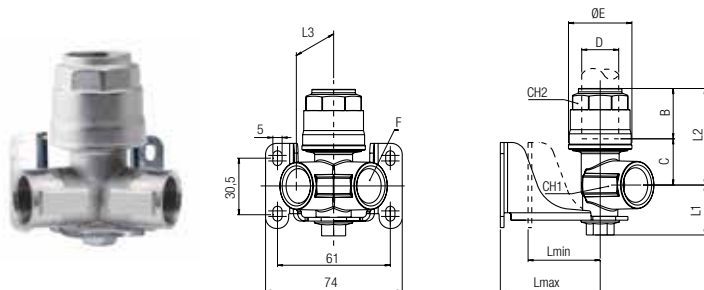

90660

RIPARTITORE 2 VIE INCLINATO ATTACCO TUBO - FEMMINA

2 WAYS INCLINED MANIFOLD TUBE-FEMALE
 WANDANSCHLUSS 2-FACH MIT ROHRANSCHLUSS 45°
 PRISE MURALE, 2 SORTIES FEMELLES 45°
 REPARTIDOR A 2 VÍAS INCLINADO CONEXIÓN TUBO-HEMBRA
 SAÍDA DE AR DUPLA INCLINADA TUBO-ROSCA FÊMEA

Code	D	F	B	C	E	L1	L2	L3	Lmin	Lmax	CH	Pack.
90660 00 001	20	1/2	31.5	34.5	34.5	31	66	37.5	22	54	30	2
90660 00 002	25	1/2	38.5	33	42.5	31	71.5	37.5	22	54	35	2

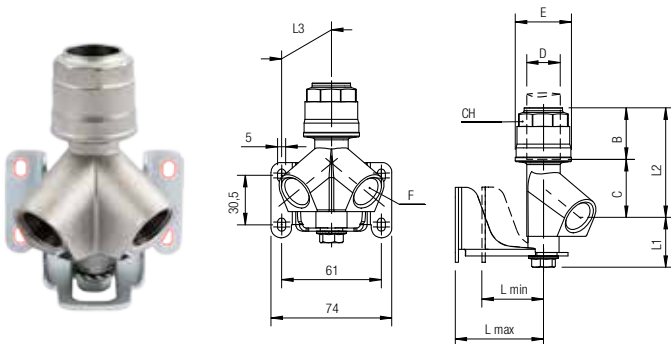

90661

NPTF

RIPARTITORE 2 VIE INCLINATO ATTACCO TUBO - FEMMINA

2 WAYS INCLINED MANIFOLD TUBE-FEMALE
 WANDANSCHLUSS 2-FACH MIT ROHRANSCHLUSS 45°
 PRISE MURALE, 2 SORTIES FEMELLES 45°
 REPARTIDOR A 2 VÍAS INCLINADO CONEXIÓN TUBO-HEMBRA
 SAÍDA DE AR DUPLA INCLINADA TUBO-ROSCA FÊMEA

Code	D	F (NPTF)	B	C	E	L1	L2	L3	Lmin	Lmax	CH	Pack.
90661 00 001	20	1/2	31.5	34.5	34.5	31	66	37.5	22	54	30	2
90661 00 002	25	1/2	38.5	33	42.5	31	71.5	37.5	22	54	35	2

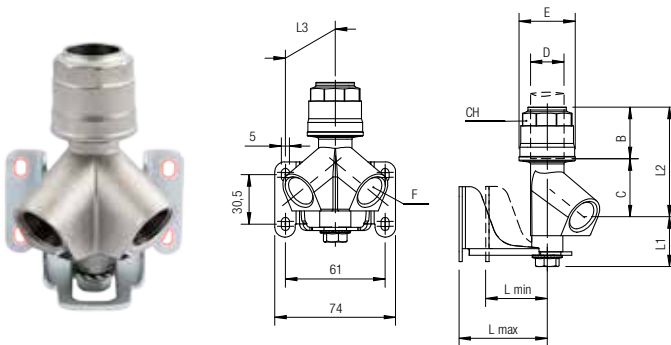

90662

RIPARTITORE 2 VIE INCLINATO ATTACCO FEMMINA

2 WAYS INCLINED MANIFOLD FEMALE

WANDANSCHLUSS 2-FACH MIT INNENGEWINDE 45°

PRISE MURALE, 2 SORTIES TARAUDÉES 45°

REPARTIDOR A 2 VÍAS INCLINADO CONEXIÓN HEMBRA

SAÍDA DE AR DUPLA INCLINADA ROSCA FÊMEA

Code	A	F	B	E	L1	L2	L3	L _{min}	L _{max}	Pack.
90662 00 001	1/2	1/2	13	32	31	40.5	37.5	22	54	2
90662 00 002	3/4	1/2	16.5	32	31	39	37.5	22	54	2

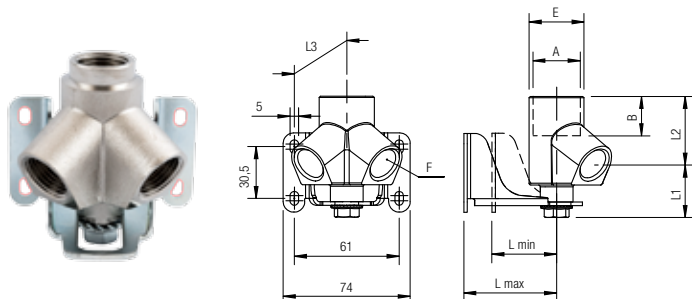

90663

NPTF

RIPARTITORE 2 VIE INCLINATO ATTACCO FEMMINA

2 WAYS INCLINED MANIFOLD FEMALE

WANDANSCHLUSS 2-FACH MIT INNENGEWINDE 45°

PRISE MURALE, 2 SORTIES TARAUDÉES 45°

REPARTIDOR A 2 VÍAS INCLINADO CONEXIÓN HEMBRA

SAÍDA DE AR DUPLA INCLINADA ROSCA FÊMEA

Code	A (NPTF)	F (NPTF)	B	E	L1	L2	L3	L _{min}	L _{max}	Pack.
90663 00 001	1/2	1/2	13.5	32	31	40.5	37.5	22	54	2
90663 00 002	3/4	1/2	14	32	31	39	37.5	22	54	2

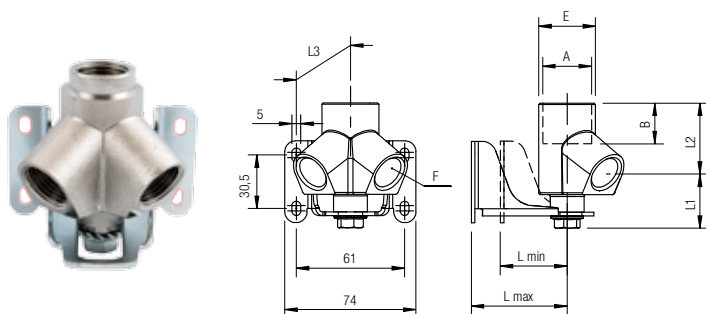

90664

RIPARTITORE 2 VIE INCLINATO CON VALVOLA - FEMMINA

2 WAYS INCLINED MANIFOLD VALVE-FEMALE

WANDANSCHLUSS 2-FACH 45° MIT MONTIERTEM KUGELHAHN

PRISE MURALE, 2 SORTIES FEMELLES 45°, AVEC ROBINET

REPARTIDOR A 2 VÍAS INCLINADO CONEXIÓN HEMBRA

SAÍDA DE AR DUPLA INCLINADA ROSCA FÊMEA COM VÁLVULA ACOPLADA

Code	D	F	B	E	L1	L2	L3	L4	L5	L _{min}	L _{max}	CH	Pack.
90664 00 001	20	1/2	31.5	34.5	31	40.5	37.5	84.5	184	22	54	30	2
90664 00 002	25	1/2	38.5	42.5	31	39	37.5	101.5	209	22	54	35	2

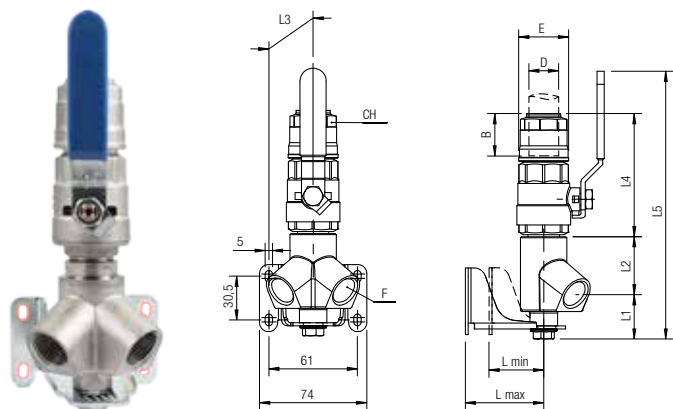

90665

NPTF

RIPARTITORE 2 VIE INCLINATO CON VALVOLA - FEMMINA

2 WAYS INCLINED MANIFOLD VALVE-FEMALE
 WANDANSCHLUSS 2-FACH 45° MIT MONTIERTEM KUGELHAHN
 PRISE MURALE, 2 SORTIES FEMELLES 45°, AVEC ROBINET
 REPARTIDOR A 2 VÍAS INCLINADO CONEXIÓN HEMBRA
 SAÍDA DE AR DUPLA INCLINADA ROSCA FÊMEA COM VÁLVULA ACOPLADA

Code	D	F (NPTF)	B	E	L1	L2	L3	L4	L5	L _{min}	L _{max}	CH	Pack.
90665 00 001	20	1/2	31.5	34.5	31	40.5	37.5	84.5	184	22	54	30	2
90665 00 002	25	1/2	38.5	42.5	31	39	37.5	101.5	209	22	54	35	2

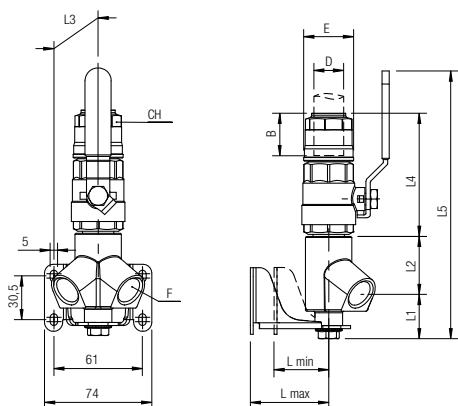

**ORIENTABILE
 ADJUSTABLE
 EINSTELLBAR
 ORIENTABLE
 AJUSTABLE
 ORIENTÁVEL**

90700

VALVOLA A SFERA - PASSAGGIO TOTALE

BALL VALVE TUBE/TUBE
 KUGELHAHN - VOLLER DURCHGANG
 ROBINET DOUBLE EGAL - PLEIN PASSAGE
 VÁLVULA DE BOLA A 2 VÍAS TUBO/TUBO
 VÁLVULA DE ESFERA

Code	D	DN	B	C	E	L	CH1	CH2	G	H	Pack.
90700 00 001	20	17	31.5	58.5	34.5	121.5	32	30	88	42	2
90700 00 002	25	22	38.5	61.5	42.5	138.5	41	35	106	47.5	2
90700 00 003	32	29	46	75	52	167	50	45	106	53	2
90700 00 004	40	37	52.5	81	63	186	59	55	134	65	1
90700 00 005	50	46	63.5	103	73	230	69	65	134	72.5	1
Alluminio - Aluminium - Aluminium - Aluminium - Aluminium - Alumínio											
90700 00 006 A	63	59	57.5	126	94	232	89	75	240	111.5	1

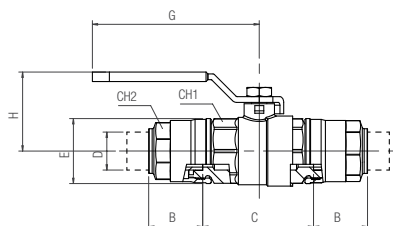

90705

New

VALVOLA A SFERA - PASSAGGIO TOTALE - CON LUCCHETTO

BALL VALVE TUBE/TUBE WITH PADLOCK

KUGELHAHN - VOLLER DURCHGANG INKL. VORHÄNGESCHLOSS

ROBINET DOUBLE EGAL - PLEIN PASSAGE INCL. CADENAS

VÁLVULA DE BOLA A 2 VÍAS TUBO/TUBO CANDADO INCLUIDO

VÁLVULA DE ESFERA CADEADO INCLUSO

Code	D	DN	B	C	E	L	CH1	CH2	G	H	I	M	Pack.
90705 00 001	20	17	31.5	58.5	34.5	121.5	32	30	88	42	50.7	45	2
90705 00 002	25	22	38.5	61.5	42.5	138.5	41	35	106	47.5	59.5	45	2
90705 00 003	32	29	46	75	52	167	50	45	106	53	65	45	2
90705 00 004	40	37	52.5	81	63	186	59	55	134	65	74.5	47	1
90705 00 005	50	46	63.5	103	73	230	69	65	134	72.5	82	47	1

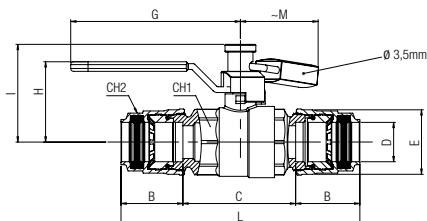

90710

VALVOLA A FARFALLA + VITI + DADI + RONDELLE

BUTTERFLY VALVE + SCREWS + NUTS + WASHERS

ABSPERKLAPPE + SCHRAUBEN + MUTTERN + SCHEIBEN

VANNE A PAPILLON + VIS + ECROU + RONDELLES

VÁLVULA MARIPOSA + TORNILLOS + TUERCAS + ARANDELAS

VÁLVULA BORBOLETA + PARAFUSOS + PORCAS + ARRUELAS

Code	D	DN	A	B	C	E	F	Pack.
90710 00 002	80	77	87	216	46	160	210	1
90710 00 001	110	100	106	201	52	180	210	1

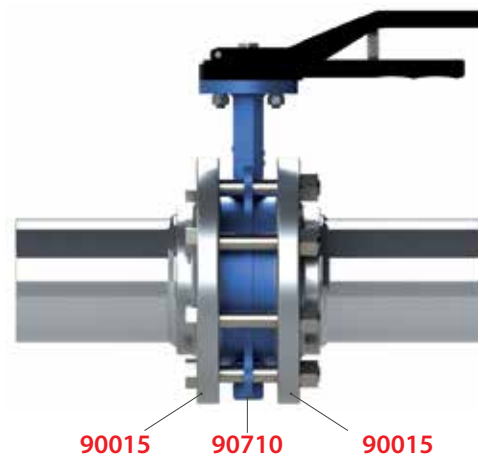
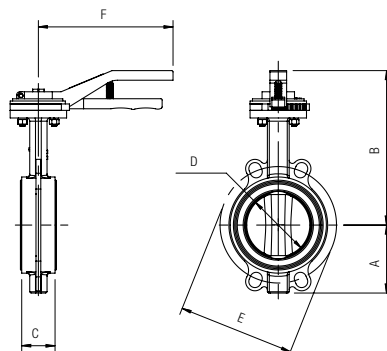

90720

VALVOLA A SFERA MASCHIO-TUBO

MALE-TUBE BALL VALVE

KUGELHAHN AUSSENGEWINDE-ROHR

VANNE TUBE / FILETAGE

VÁLVULA DE BOLA A 2 VÍAS MACHO-TUBO

VÁLVULA DE ESFERA ROSCA MACHO-TUBO

Code	D	F	DN	A	B	C	E	L	CH1	CH2	G	H	Pack.
90720 00 001	20	1/2	15	18	31.5	29.3	34.5	100.8	32	30	88	42	2
90720 00 002	25	3/4	20	18	38.5	30.8	42.5	119.3	41	35	106	47.5	2

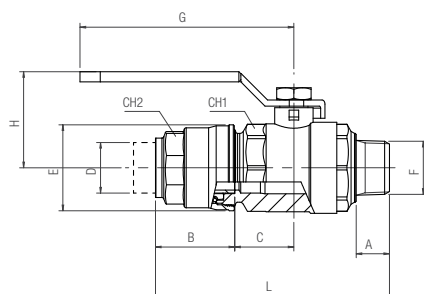

90721

NPTF

VALVOLA A SFERA MASCHIO-TUBO

MALE-TUBE BALL VALVE
KUGELHAHN AUSSENGEWINDE-ROHR
VANNE TUBE / FILETAGE
VÁLVULA DE BOLA A 2 VÍAS MACHO-TUBO
VÁLVULA DE ESFERA ROSCA MACHO-TUBO

Code	D	F (NPTF)	DN	A	B	C	E	L	CH1	CH2	G	H	Pack.
90721 00 001	20	1/2	15	17	31.5	29.3	34.5	100.8	32	30	88	42	2
90721 00 002	25	3/4	20	17.5	38.5	30.8	42.5	119.3	41	35	106	47.5	2

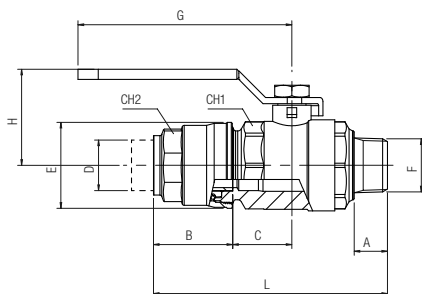

90725

New

VALVOLA A SFERA MASCHIO-TUBO CON LUCCHETTO

MALE-TUBE BALL VALVE WITH PADLOCK
KUGELHAHN AUSSENGEWINDE-ROHR INKL. VORHÄNGESCHLOSS
VANNE TUBE / FILETAGE INCL. CADENAS
VÁLVULA DE BOLA A 2 VÍAS MACHO-TUBO CANDADO INCLUIDO
VÁLVULA DE ESFERA ROSCA MACHO-TUBO CADEADO INCLUSO

Code	D	F	DN	A	B	C	E	L	CH1	CH2	G	H	I	M	Pack.
90725 00 001	20	1/2	15	18	31.5	29.3	34.5	100.8	32	30	88	42	50.7	45	2
90725 00 002	25	3/4	20	18	38.5	30.8	42.5	119.3	41	35	106	47.5	59.5	45	2

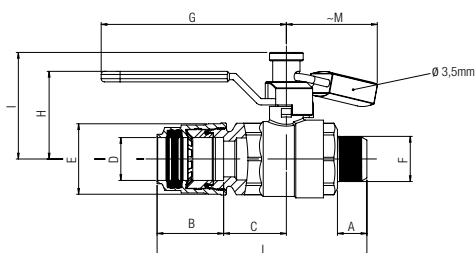

90726

New

NPTF

VALVOLA A SFERA MASCHIO-TUBO CON LUCCHETTO

MALE-TUBE BALL VALVE WITH PADLOCK
KUGELHAHN AUSSENGEWINDE-ROHR INKL. VORHÄNGESCHLOSS
VANNE TUBE / FILETAGE INCL. CADENAS
VÁLVULA DE BOLA A 2 VÍAS MACHO-TUBO CANDADO INCLUIDO
VÁLVULA DE ESFERA ROSCA MACHO-TUBO CADEADO INCLUSO

Code	D	F (NPTF)	DN	A	B	C	E	L	CH1	CH2	G	H	I	M	Pack.
90726 00 001	20	1/2	15	17	31.5	29.3	34.5	100.8	32	30	88	42	50.7	45	2
90726 00 002	25	3/4	20	17.5	38.5	30.8	42.5	119.3	41	35	106	47.5	59.5	45	2

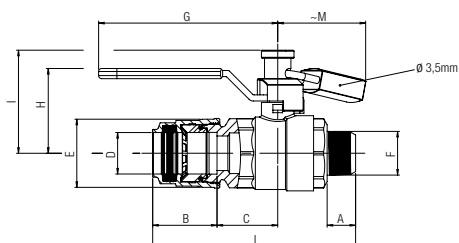

New

INFINITY VALVE

90740

Code	D	Kv	A	B	C	E	F	CH2	Pack.
90740 00 003	32	78	198	46	89	52	92,6	45	1
90740 00 004	40	101	208	52	89	63	92,6	55	1
90740 00 005	50	168	249	63,5	109	73	110	65	1
90740 00 006	63	300	269	57,5	139	94	140,3	75	1



Pressure

15 bar (1.5 MPa)

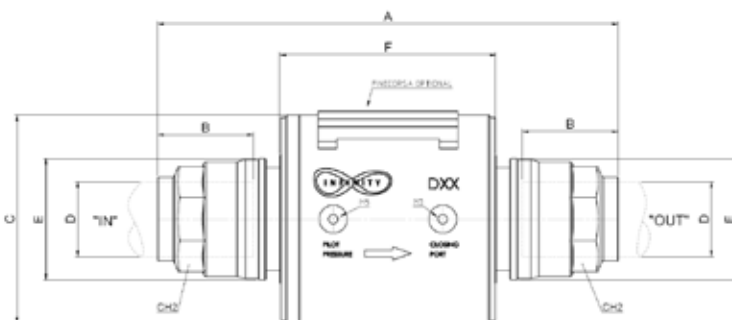

Funzionamento

IT

La valvola si presenta come una normalmente chiusa e sfrutta la pressione presente in condotta per l'apertura o l'interruzione del flusso di aria compressa.

La valvola, se non opportunamente pilotata, inizia spontaneamente a commutare il suo stato in valvola aperta quando la pressione in condotta raggiunge circa 2 bar e raggiunge la condizione di massima portata con pressione in condotta di circa 3,5 bar.

Da notare che se la pressione scende a circa 2 bar la valvola automaticamente richiude; quindi in caso di guasto, le sezioni non direttamente interessate dalla perdita vengono mantenute con una pressione minima pari a questo valore.

La pressione presente in condotta è sempre disponibile sull'uscita "pilot pressure"; mediante un semplice deviatore pneumatico o elettro-pneumatico è possibile indirizzare questa pressione verso la "closing port" ottenendo l'immediata chiusura della valvola.

Function

GB

The valve is normally closed and it uses the pipeline pressure to open and close the compressed air flow.

If not piloted, with a min. pressure of 2 bar the valve transits from closed to open position spontaneously. The valve is fully open with pipeline pressure around 3.5 bar.

If pressure drops under 2 bar the valve automatically closes. This is the minimum pressure that remains in pipeline sections not affected by failure.

The pipeline pressure is always available on the outlet "Pilot Pressure". Using a pneumatic or electro-pneumatic deflector is possible to flow this pressure to the "Closing Port" in order to close the valve immediately.

Funktion

DE

Das Ventil ist normalerweise geschlossen, wobei zum Öffnen und Schliessen des Druckluftstroms der Leitungsdruck verwendet wird.

Wenn nicht mit einem Mindestdruck von 2 bar gesteuert, wechselt das Ventil spontan von der geschlossenen in die geöffnete Position. Das Ventil ist vollständig geöffnet bei einem Leitungsdruck um 3,5 bar.

Wenn der Druck unter 2 bar fällt, schliesst das Ventil automatisch. Dies ist der Mindestdruck, der in den Rohrleitungsabschnitten bleibt, welche nicht durch den Ausfall betroffen sind.

Der Leitungsdruck ist immer auf dem Ausgang "Steuerdruck". Durch den Einsatz eines einfachen pneumatischen oder elektropneumatischen Schalters, ist es möglich diesen Druck auf den "Closing Port" zu leiten, damit das Ventil sofort schliesst.

Exécutions

FR

La vanne clapet est normalement fermée et exploite la pression dans le conduit pour l'ouverture ou la fermeture du débit d'air.

La vanne, si non pilotée, passe graduellement de la position fermée en position ouverte à une pression minimale de 2 bars et atteint les conditions de plein débit dès que la pression minimale est de 3,5 bars.

Notez que si la pression tombe à 2 bars environs, le clapet se ferme automatiquement. Donc en cas de panne, les parties du réseau non directement concernées par la perte sont maintenues avec une pression minimale égale à cette valeur.

La pression à l'intérieur du tube est toujours disponible à la sortie "pilot pressure". Grace à un simple dispositif pneumatique ou électro-pneumatique vous pouvez diriger cette pression vers le "closing port" pour obtenir la fermeture immédiate de la vanne.

Funcionamiento

ES

La válvula es normalmente cerrada y utiliza la presión del circuito para abrir y cerrar el flujo de aire comprimido.

Si no está pilotada, con una presión mínima de 2 bar la válvula se abre de inmediato. La válvula estará totalmente abierta cuando la presión llega a los 3,5 bar.

Si la presión cae por debajo de los 2 bar la válvula se cierra automáticamente. Esta es la presión mínima que permanece en las secciones de tubería no afectadas por el fallo.

La presión de la tubería está siempre disponible en la salida de la "presión de pilotaje". Utilizando un deflector neumático o electro-neumático es posible fluir esta presión hacia el cierre en modo de cerrar la válvula inmediatamente.

Funcionamento

PT

A válvula está normalmente fechada e utiliza a pressão da rede para abrir e fechar o fluxo de ar comprimido.

Se não for pilotada com uma pressão mínima de 2 bar, a válvula comuta da posição aberta para a posição fechada espontaneamente. A válvula é completamente aberta com uma pressão de rede de cerca de 3,5 bar.

Se a pressão descer abaixo de 2 bar a válvula automaticamente fecha. Esta é a pressão mínima que permanece em seções da rede não afetadas por falha.

A pressão de rede está sempre disponível na saída "Pilot Pressure" (Pressão Piloto).

Usando um defletor pneumático ou eletro-pneumático é possível direcionar esta pressão para a conexão "Closing Port" (Via de Fechamento), de maneira a fechar a válvula imediatamente.

Valvola chiusa

Closed Valve
Geschlossenes Ventil
Vanne fermée
Válvula cerrada
Válvula fechada

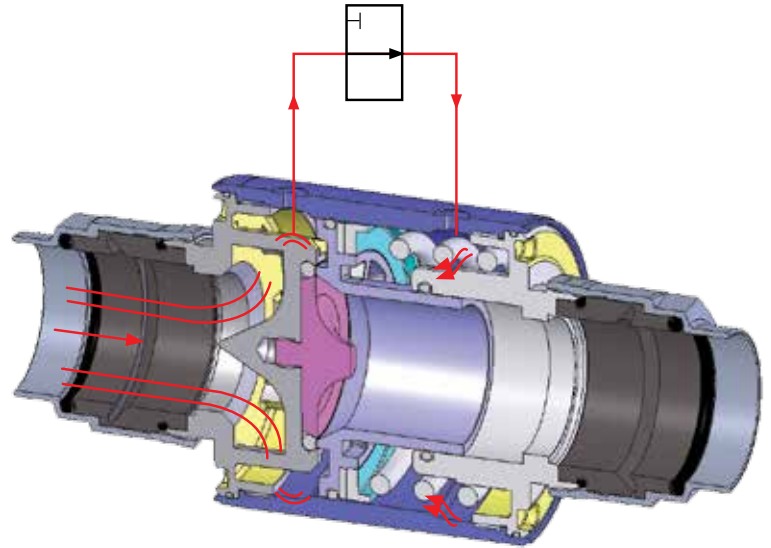

Valvola aperta con pressione in linea maggiore di 2 bar

Open valve with inline pressure higher than 2 bar
Offene Ventile mit einem Inline-Arbeitsdruck höher als 2 bar
Vanne ouverte avec pression en ligne supérieure à 2 bar
Válvula abierta con una presión en la línea superior a 2 bar
Válvula aberta com uma pressão em linha superior a 2 bar

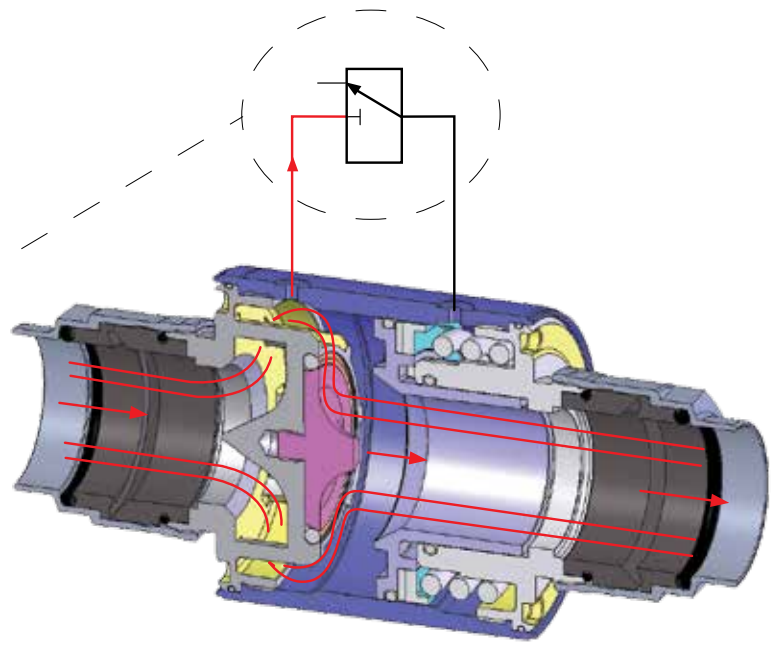

MICROVALVOLE PER ATTUATORE DA PANNELLO

MICROVALVE FOR PANEL MOUNTING ACTUATOR
STÖSSEL - MIKROVENTIL, SCHALTAFELEINBAU
MICRODISTRIBUTEUR À POUSSOIR, MONTAGE EN PANNEAU
MICROVÁLVULA PARA ACTUADORES DE PANEL
MICRO-VÁLVULA PARA ATUADOR DE PAINEL



SELETORE A CHIAVE

KEY SELECTOR
SCHLÜSSELSCHALTER
BOUTON TOURNANT, À CLÉ
SELECTOR DE LLAVE
SELETOR COM CHAVE



Codice Code Nummer Code Código Código	Vie Ways Wege Voies Vías Vías	Funzione Function Funktion Fonction Función Funções	Misura Size Größe Dimension Medida Tamanho	Pack.
02V DO 3 NC B5	3/2	NC	M5	1

Codice Code Nummer Code Código Código	Colore Color Farbe Couleur Colores Cores	Funzione Function Funktion Fonction Función Funções	Posizione estrazione chiave Position to pull the key out Schlüsselabnahme Retrait de clé Posición extracción llave Posição de retirada da chave	Pack
04V 03 0 00 02	■	0 - 1	Ambedue - Both position Beide- Les deux Ambas posiciones - Ambas as posições	1

90790

New

RIPARTITORE DIRITTO 4 VIE

4 WAYS DISTRIBUTION MANIFOLD

VERTEILERBLOCK 4-FACH

NOURRICE DE DISTRIBUTION 4 SORTIES

REGLETA SIMPLE 4 SALIDAS

DISTRIBUIDOR QUADRUPLA

Code	F	A	B	C	L	I	Pack.
90790 00 001	3/4	1/2	25	31	34	164	38 1
90790 00 002	1"	1/2	30	37,5	37	174	38 1
90790 00 003	1"-1/4	1/2	30	47	50	210	50 1

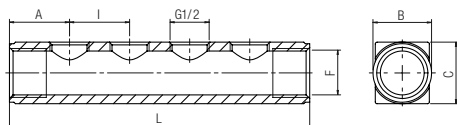

90800

TUBO EVITA OSTACOLI A C

"C" TUBE TO AVOID OBSTACLES

VORGEBOGENE ROHRE FORM C

TUBE PRÉ-CINTRÉ EN C

TUBO EVITA OBSTÁCULO "C"

TUBO PARA DESVIO DE OBSTÁCULOS EM "C"

Code	D	A	B	C	E	Pack.
90800 00 11 Y9 B5	20	75	760	254	250	1
90800 00 11 J4 B5	25	75	743	240	250	1

Fino ad esaurimento scorta

Until the end stock

Nur solange vorrat

Livrable jusqu'à épuisement du stock

Hasta fin de stock

Ate fim do stock

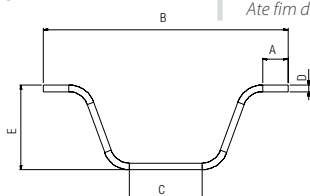
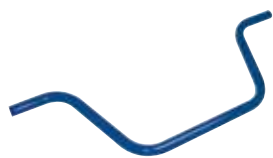

90805

TUBO EVITA OSTACOLI A U

"U" TUBE TO AVOID OBSTACLES

VORGEBOGENE ROHRE FORM U

TUBE PRÉ-CINTRÉ EN U

TUBO EVITA OBSTÁCULO "U"

TUBO PARA DESVIO DE OBSTÁCULOS EM "U"

Code	D	A	B	C	E	Pack.
90805 00 11 Y9 B5	20	690	753	394	605	1
90805 00 11 J4 B5	25	690	755	389	604	1
90805 00 11 J9 B5	32	690	773	352	604	1
90805 00 11 K4 B5	40	690	784	289	583	1

Fino ad esaurimento scorta

Until the end stock

Nur solange vorrat

Livrable jusqu'à épuisement du stock

Hasta fin de stock

Ate fim do stock

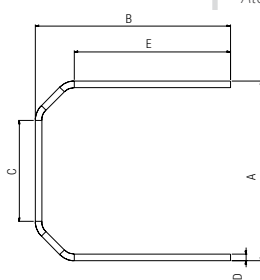
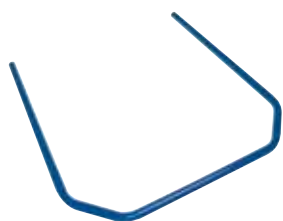

90815

COLLAR IN TECNOPOLIMERO CON DADO M6

COLLAR MADE IN TECHNOPOLYMERIC WITH M6 NUT

ROHRBEFESTIGUNG TECHNOPOLYMER + MUTTER M6

COLLIER DE FIXATION EN THERMOPLASTIQUE AVEC ECROU M6

COLLAR EN TECNOPOLIMERO CON TUERCA M6

SUPOORTE TIPO ABRAÇADEIRA EM TECNOPOLÍMERO COM PORCA M6

Code	Tube	A	B	C	Pack.
90815 00 001	20	15	35.5	26	5
90815 00 002	25	17	39.5	26	5
90815 00 003	32	20	44.5	40	5
90815 00 004	40	24.5	53.5	40	5
90815 00 005	50	30	62	54	5
90815 00 006	63	36	73.5	54	5

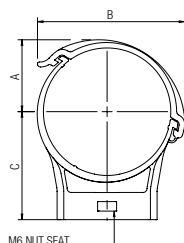

90817

DISTANZIALE PER COLLARE 90815 IN TECNOPOLIMERO

SPACER FOR COLLARS 90815 MADE IN TECHNO-POLYMERIC
 ADAPTER FÜR ROHRBEFESTIGUNG TECHNO-POLYMER 90815
 CALE D'ADAPTATION POUR COLLIER DE FIXATION 90815
 DISTANCIAL PARA COLLAR 90815 EN TECNOPOLÍMERO
 ESPAÇADOR PARA SUPORTE ABRAÇADEIRA 90815 EM TECNOPOLÍMERO

Code	C	Pack.
90817 00 001	14	5

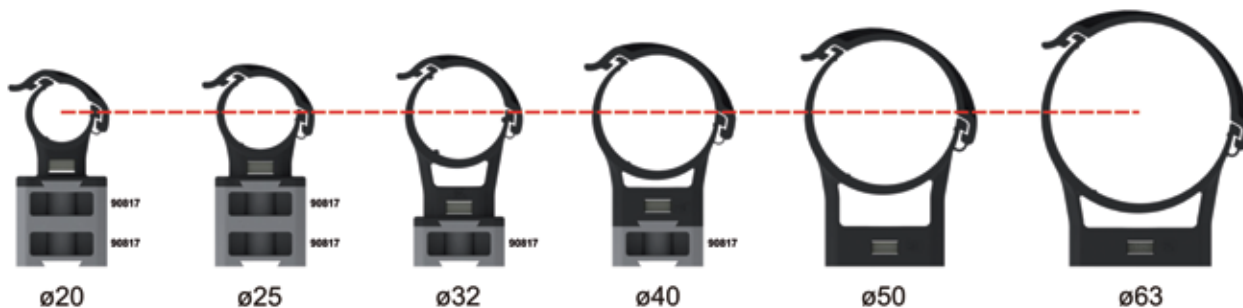
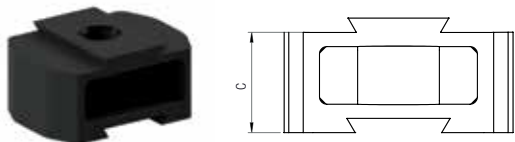

90820

COLLARE IN ACCIAIO

COLLAR MADE IN STEEL
 ROHRBEFESTIGUNG AUS STAHL
 COLLIER DE FIXATION
 COLLAR EN ACERO
 SUPORTE TIPO ABRAÇADEIRA EM AÇO

Code	Tube	H	A	Pack.
90820 00 001	20	M8 / M10	28.5	5
90820 00 002	25	M8 / M10	31	5
90820 00 003	32	M8 / M10	34.5	5
90820 00 004	40	M8 / M10	39.5	5
90820 00 005	50	M8 / M10	44	5
90820 00 006	63	M8 / M10	51	5
90820 00 007	80	M8 / M10	71	4
90820 00 008	110	M8 / M10	81.5	2

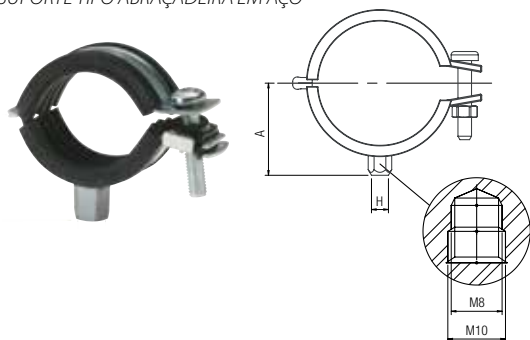

POSIZIONAMENTO COLLARI - COLLAR POSITIONS - POSITIONIERUNG DER BEFESTIGUNGEN
 POSITIONS DES COLLIERS - POSICIONAMENTO COLLARES - POSICIONAMENTO DOS SUPORTES

Tubo da 4 m
 4 m Tube
 Rohr 4 m
 Tube 4 m
 Tubo de 4 m
 Tubo de 4 m

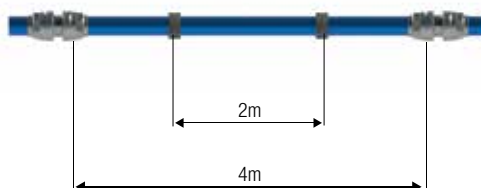

Tubo da 6 m
 6 m Tube
 Rohr 6 m
 Tube 6 m
 Tubo de 6 m
 Tubo de 6 m

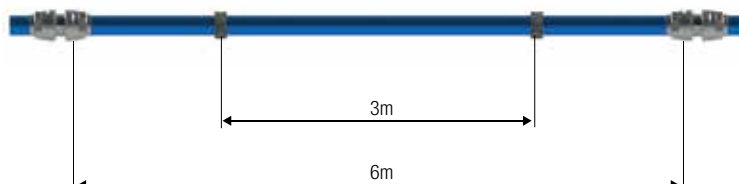

AVVOLGITUBO

 HOSE REEL
 SCHLAUCHAUFROLLER
 ENROULEURS
 RECOGETUBOS
 MANGUEIRAS

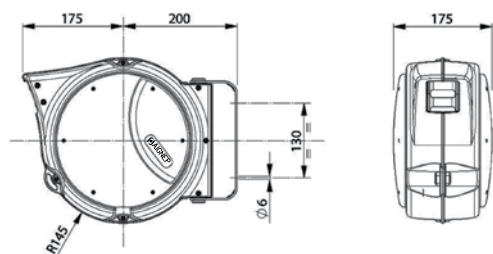
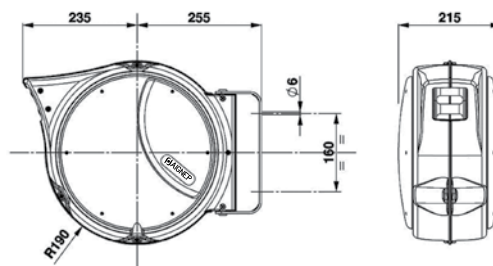
Code: 90825 00 001 9+1

Code: 90825 00 003 15+1

	90825 00 001 9+1	90825 00 003 15+1
Tubo poliuretano Polyurethane tube Rohr Polyurethan Tube polyuréthane Tubo poliuretano Tubo poliuretano	Ø INT. 8mm (5/16") Ø EXT. 12mm	Ø INT. 10mm Ø EXT. 14mm
Lunghezza tubo (m) Tube length (m) Rohr Länge (m) Longueur de tube (m) Longitud tubo (m) Comprimento de tubo (m)	9+1	15+1
Pressione massima Max pressure Max. Druck Pressions maximale Presión máxima Máx. Press.	15 bar (1.5 MPa)	
Temperatura Temperature Temperatur Température Temperatura Temperatura	- 5 °C + 40 °C	
Raccordo in uscita Outlet fitting Anschluss beim Ausgang Raccordement amont Conector de salida Conexão de saída	1/4 M	3/8 M

	90825 00 001 9+1	90825 00 003 15+1
Raccordo in entrata Inlet fitting Anschluss beim Eingang Raccordement aval Conector de entrada Conexão de entrada	NO	
Spezzione ingresso Cut down size tube Länge des Eingangsrohres Longueur du tube en amont Extremo del tubo Comprimento de entrada	1.5 m	
Aria Air Luft Air Aire Ar	SI	
Conf. Pack. Verp. Cond. Embalaje Embal.	390x330x230 mm Kg 4.5	500x450x255 mm Kg 8.0
Portata a 6 bar 6 bar flow rate Durchflusswert bei 6 bar Débit à 6 bar Caudal a 6 bar Vazão a 6 bar	450 NI/min	610 NI/min

IT

- Staffa di fissaggio metallica orientabile
- Dispositivo automatico di arresto del tubo alla lunghezza desiderata. Questo dispositivo è facilmente disinseribile, qualora si voglia il tubo costantemente in trazione.

GB

- Metal swivel fixing bracket
- Automatic device to stop tube at chosen length. This device is easy to disconnect whenever you may need tube in constant traction.

DE

- Drehbarer Metallbügel
- Mit einer Verriegelungsvorrichtung um das Rohr bei der gewünschten Länge zu stoppen. Dieses Gerät kann leicht demontiert werden, um einen gleichmäßigen Zug auf dem Rohr zu haben.

FR

- Embase métallique pivotante
- Equipé d'un dispositif de blocage du tuyau à la longueur souhaitée. Ce dispositif peut être facilement démonté afin d'obtenir une traction constante sur le tuyau.

ES

- Soporte de metal para fijar.
- Dispositivo automático para detener el tubo y elegir el largo

PT

- Suporte de fixação metálico orientável
- Dispositivo automático de parada de tubo na posição desejada. Este dispositivo é facilmente desconectado, quando se necessita do tubo em constante tração.

BILANCIATORE CON TUBO SPIRALATO

BALANCER WITH COILED TUBING
 FEDERZUG MIT SPIRALROHR
 ENROULEUR ÉQUILIBREUR AVEC TUBE SPIRALÉ
 BALANCEADOR CON TUBO EN ESPIRAL
 ALACIM CON TUBO ESPIRALADO

Code: 90826

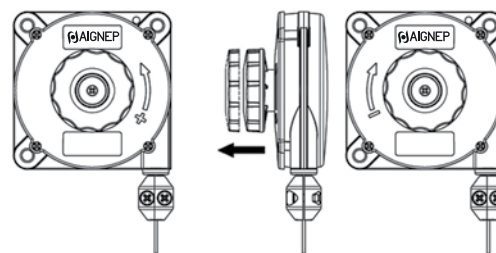
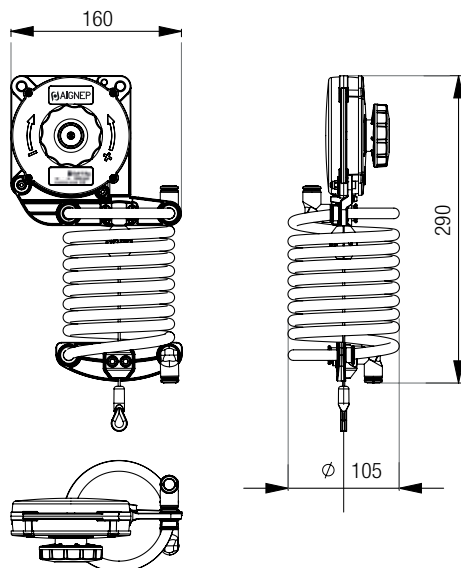
Regolazione del carico

Adjusting the load
 Einstellen der Last
 Réglage de la charge
 Ajuste de la carga
 Ajuste da carga

	90826 00 001	90826 00 002	90826 00 003
Portata (Kg) Capacity (Kg) Kapazität (Kg) Capacité (Kg) Caudal (Kg) Vazão (Kg)	0.4 ÷ 1	1 ÷ 2	2 ÷ 3
Cavo in acciaio Stainless steel rope Stahlseil Câble en acier Cable de acero inoxidable Cabo de aço inoxidável		Ø 2 mm	
Corsa cavo Stroke rope Hublänge Course Longitude cable Largura cabo		1600 mm	
Tubo PA12 Tube Rohr Tube Tubo Tubo		Ø INT. 8 mm (5/16") Ø EXT. 10 mm	
Pressione massima Max pressure Druckbereich max Pressions maximale Presión máxima Máx. Press.		10 bar (1 MPa)	

	90826 00 001	90826 00 002	90826 00 003
Raccordo entrata-uscita Inlet-outlet fitting Anschluss IN/OUT Connexion IN/OUT Conexiones entrada/salida Conexão de saída/entrada		Raccordo automatico Ø 10 Push-in fitting Ø 10 Steckverschraubungen Ø10 Raccords instantanés Ø 10 Racordaje automático Ø 10 Conexões Push-in Ø 10	
Spezzone ingresso Cut down size tube Anpassung Adaptable Extremo del tubo Comprimento de entrada		1 m	
Aria Air Luft Air Aire Ar		SI	
Conf. Pack. Verp. Cond. Embalaje Embal.		1	

90830

MENSOLA

BRACKET
HALTERUNGSSCHIENE
RAIL DE FIXATION
SOPORTE
SUPORTE

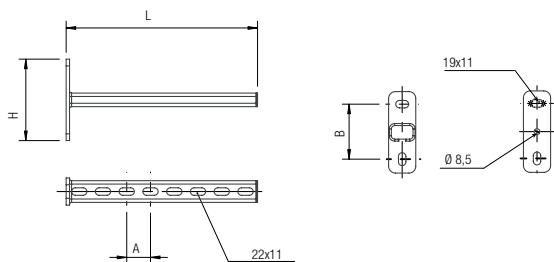

Code	A	B	H	L	Pack.
90830 00 001	35	81	120	280	1

90860

MORSETTO

CLAMP HANGER
KLEMMEN MIT BOHRUNG
PINCE A VISSER
BRIDA DE SUJECCIÓN (AGUJERO PASANTE)
SUPORTE DE FIXAÇÃO

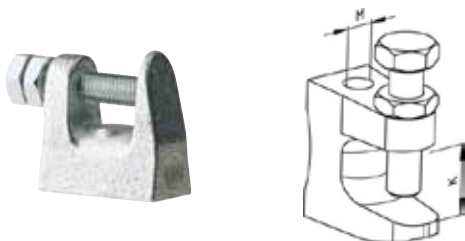

Code	M	K	Pack.
90860 00 001	Ø9	18	5

90861

MORSETTO FILETTATO

THREADED CLAMP HANGER
KLEMMEN MIT GEWINDE
PINCE A VISSER
BRIDA DE SUJECCIÓN (AGUJERO ROSCADO)
SUPORTE DE FIXAÇÃO ROSCADO

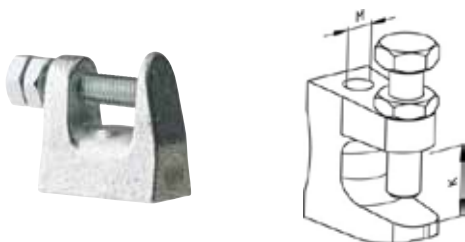

Code	M	K	Pack.
90861 00 001	M8	18	5

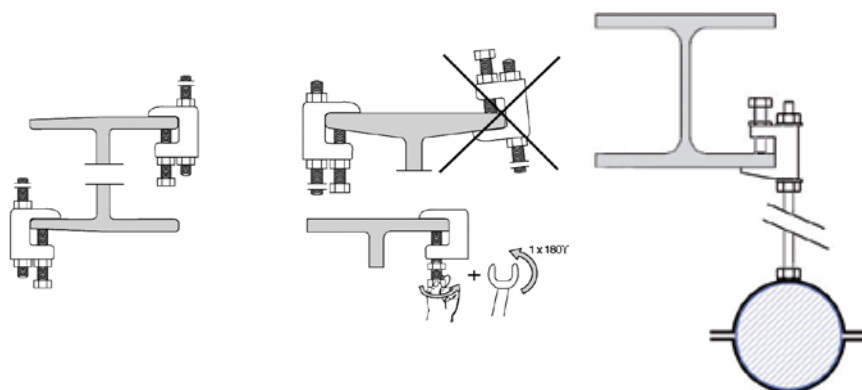

90870

TAGLIATUBO

PIPE CUTTER
ROHRABSCHNEIDER
COUPE-TUBE
CORTATUBOS
CORTADOR DE TUBO



Code		Pack.
90870 00 001	20 - 63	1
90870 00 002	50 - 110	1

90880

SBAVATORE TUBO

DE-BURRER
ROHRENTGRATER
OUTIL D'ÉBAVURAGE
DESBARBADOR
DESBASTADOR DE TUBOS



Code	Pack.
90880 00 001	20 - 25 - 32 - 40 1

90885

DIMA SEGNA TUBO

DIMA MARK TUBE
MARKIERUNGSWERKZEUG
GABARIT DE MARQUAGE
MARCATUBO
GUIA PARA CORTE DE TUBO

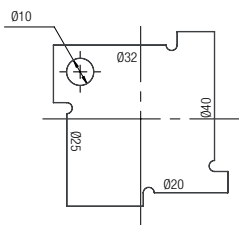

Code	Pack.
90885 00 001	20 - 25 - 32 - 40 1

VAL01

VALIGETTA ESPOSITIVA

DEMO CASE
DEMONSTRATIONSKOFFER
COFFRE DE DÉMONSTRATION
MALETA EXPOSITOR
MALETA EXPOSITORA



Code	Pack.
VAL01	1

VAL03

VALIGETTA KIT UTENSILI INFINITY

TOOLS KIT INFINITY CASE
WERKZEUGKOFFER
COFFRE D'OUTILLAGE
MALETA KIT ÚTILES INFINITY
MALETA FERRAMENTAS



Code	Pack.
VAL03	1

90889

ETICHETTA ADESIVA INFINITY VACUUM

LABEL INFINITY VACUUM
 AUFKLEBER - VAKUUM
 ETIQUETA VACÍO
 ETIQUETA ADESIVA VACUO
 ETIQUETA ADESIVA INFINITY VÁCUO



Code

90889 00 001

Pack.

10

90892

New

SEPARATORE CONDENSA

WATER SEPARATOR
 WASSERABSCHNEIDER
 SEPARATEUR CONDENSAT
 SEPARADOR DE CONDENSADOS
 SEPARADOR DE ÁGUA



Code	F	A	B	C	Flow rate (l/min)	Pack.
90892 00 001	3/4	95	220	197	1300	1
90892 00 002	3/4	95	280	257	2800	1
90892 00 003	1" 1/2	125	310	285	5100	1
90892 00 004	1" 1/2	125	397	367	10500	1
90892 00 005	2"	170	520	478	21100	1
90892 00 006	2" 1/2	199	985	930	30000	1
90892 00 007	3"	199	985	930	47000	1

New

VALVOLA DI SCARICO CONDENSA

CONDENSED DRAIN VALVE
 ABLASSVENTIL
 ROBINET DE VIDANGE
 VÁLVULA DE VACIADO
 VÁLVULA DE DRENAGEM

CARATTERISTICHE TECNICHE
 TECHNICAL CHARACTERISTICS
 TECHNISCHE ANGABEN
 CARACTÉRISTIQUES TECHNIQUES
 CARACTERÍSTICAS TÉCNICAS
 CARACTERÍSTICAS TÉCNICAS



2/2 NC

Materiali e Componenti	IT	Component Parts and Materials	GB	Komponenten und Materialien	DE
1 Corpo: Ottone		1 Body: Brass		1 Körper: Messing	
2 Guarnizioni: NBR		2 Seals: NBR		2 Dichtung: NBR	
3 Tubo guida: Acciaio inox		3 Welded armature tube: Stainless steel		3 Führungsrohr: Edelstahl	
4 Nucleo fisso e mobile: Acciaio inox		4 Fixed and mobile core: Stainless steel		4 Kern: Edelstahl	
5 Molle: Acciaio inox		5 Springs: Stainless steel		5 Feder: Edelstahl	

Matériaux et Composants	FR	Materiales y componentes	ES	Materialis e Componentes	PT
1 Corps: Laiton		1 Cuerpo: Latón		1 Corpo: Latão	
2 Joints: NBR		2 Juntas: NBR		2 Vedações: NBR	
3 Tube de pilotage: Acier inox		3 Tubo guía: Acero inox.		3 Tubo Guia: Aço-inox	
4 Noyau: Acier inox		4 Núcleo fijo y móvil: Acero inox.		4 Núcleo fixo e móvel: Aço-inox	
5 Ressort: Acier inox		5 Muelle: Acero inox.		5 Mola: Aço-inox	

Bar **Pressione massima ammissibile**
 Maximum allowable pressure
 Max. Betriebsdruck
 Pression de service max.
 Presión máxima admisible
 Pressão máxima admissível

16 bar

Temperatura ambiente con bobine di classe H
 Room temperature with coil class H
 Raumtemperatur, mit Spule der Klasse H
 Température ambiente, avec bobine classe H
 Temperatura ambiente con bobina clase H
 Temperatura ambiente com bobina de classe H

**- 20 °C
 + 80 °C**

Ø **Diametro operatore**
 Operator diameter
 Durchmesser Führungsrohr
 Diamètre tube de pilotage
 Diámetro operador
 Diâmetro do operador

13 mm

✓ **Grado di filtrazione**
 Degree of filtration
 Abscheidegrad
 Degré de filtration
 Grado de filtración
 Grau de filtração

500 µm

Guarnizioni	Temperatura	Fluido
Seals	Temperature	Medium
Dichtungen	Temperatur	Medium
Joints	Température	Fluides
Juntas	Temperatura	Fluido
Vedações	Temperatura	Fluido

NBR **-10°C** **+90°C**

Aria, acqua max 75 °C, oli minerali, gasoli
 Air, inert gas, water max 75 °C, mineral oils, gas oil
 Luft, Edelgase, Wasser max. 75 °C, Mineralöle, Diesel, Heizöl
 Air, gas neutres, eau max. 75°C, huiles minerales, diesel
 Aire, gas inerte, agua máx. 75°C., aceites minerales, gasóleo
 Ar, gás inertes, água máx 75 °C, óleos minerais, gasóleo



ISTITUTO GIORDANO s.p.a.

SPECIALISTI IN RICERCA E CERTIFICAZIONE DAL 1959

Via Rossini, 2
47814 BELLARIA (RN) Italy
Tel. ++39.0541.343030 (10 linee)
Telefax ++39.0541.345540

e-mail: istitogordano@giordano.it
web site: www.giordano.it

Cod. Fisc./Part. IVA: 00.549.540.409
P.E.A. c/o C.C.I.A.A. (RN) 156766
Registro Imprese Rimini n. 00549540409
Cap. Soc. € 516.000,00 i.v.

RICONOSCIMENTI UFFICIALI:

- MINISTERO LAVORI PUBBLICI: Legge 1986/71 con D.M. 27/11/82 n. 228/3 "Prova sui materiali da costruzione"
- MINISTERO INDUSTRIA COMMERCIO ARTIGIANATO: D.M. 09/11/89 "Certificazione CEE per la qualità dei prodotti"
- MINISTERO INDUSTRIA COMMERCIO ARTIGIANATO: D.M. 31/0/91 "Certificazione CEE delle macchine utensili di macchine da ufficio"
- MINISTERO INDUSTRIA COMMERCIO ARTIGIANATO: D.L. 27/01/90 N. 130 "Certificazione CEE delle macchine utensili di macchine di sollevamento"
- MINISTERO INDUSTRIA COMMERCIO ARTIGIANATO: D.M. 06/07/90 "Certificazione CEE concernente la sicurezza dei prodotti"
- MINISTERO INDUSTRIA COMMERCIO ARTIGIANATO: D.M. 06/07/90 "Certificazione CEE in materia di recipienti semplici di recipienti liquidi e gas"
- MINISTERO INDUSTRIA COMMERCIO ARTIGIANATO: N. 15/884 del 15/10/86 "Certificazione CEE per gli apparecchi a gas"
- MINISTERO INDUSTRIA COMMERCIO ARTIGIANATO e MINISTERO LAVORO E PREVIDENZA SOCIALE: D.M. 09/07/90 "Certificazione CEE in materia di recipienti semplici di recipienti"
- MINISTERO INDUSTRIA COMMERCIO ARTIGIANATO e MINISTERO LAVORO E PREVIDENZA SOCIALE: D.M. 04/06/94 "Certificazione CEE delle macchine"
- MINISTERO INDUSTRIA COMMERCIO ARTIGIANATO: "Sostegno di attività di ricerca e sviluppo dei prodotti nell'ambito della sorveglianza sul mercato e sulla sicurezza"
- MINISTERO INDUSTRIA COMMERCIO ARTIGIANATO: D.M. 02/04/98 "Ricerca e sviluppo di conformità della compatibilità e prestazioni analogiche dei componenti degli edifici e degli impianti"
- MINISTERO INTERNO: Legge 81/84 e D.M. 26/03/86 con autorizzazione del 27/03/86, con il modulo di tutto settore D.M. 26/03/86
- MINISTERO INTERNO: Legge 81/84 e D.M. 26/03/86 con autorizzazione del 10/07/86 "Prova di resistenza ai fuoco secondo Ordine n. 91 del 14/09/85"
- MINISTERO INTERNO: Legge 81/84 e D.M. 26/03/86 con autorizzazione del 05/07/86 "Prova di resistenza al fuoco secondo Ordine n. 7 del 02/04/81 e norma CNR 91/722-134/82"
- MINISTERO INTERNO: Legge 81/84 e D.M. 26/03/86 con autorizzazione del 12/04/86 "Prova su edifici di tipo spallati secondo D.M. 20/12/86"
- MERIT: MINISTERO UNIVERSITA' E RICERCA SCIENTIFICA E TECNOLOGICA: Legge 46/82 con D.M. 09/10/85 "Formazione nell'area dei laboratori sottostesi a controllo tecnico di carattere applicativo a favore della ricerca e delle industrie"
- MINISTERO PUBBLICA ISTRUZIONE: Protocollo n. 118 del 27/04/87 "Norme alla Scheda Anagrafe Nazionale delle scuole con codice H. 8040/91"
- SINCERT (Accreditamento Organismi Certificazioni): Accreditamento n. 01/4 del 19/12/96 "Organismi di certificazione di settore qualità"
- ENAC (Sistema Nazionale per l'Accreditamento di Laboratori): Accreditamento n. 501 del 14/11/96
- DIT (Servizio di Tariffa in Italia): Accreditamento n. 20 "Centro S.T. di Ispra per garanzia termometrica ad elevata"
- ICM (Istituto di Certificazione Industriale per la Meccanica): Prova di appoggio nell'ambito degli schemi di Certificazione di Prodotto
- IRI (Istituto per il Mercato Quilici): Prova di laboratorio nell'ambito degli schemi di Certificazione di Prodotto per stoffe termici
- UNISMA (Unione Nazionale Contrattori Sanitari): Alleanza Assisi Legitt. Riconoscimento ANCI/02/85 "Laboratori per la prova di certificazione UNISMA, su schemi di facciata centrali"
- UNI (Ente Nazionale Italiano di Unificazione - Settore Certificazioni): Prova di laboratorio nell'ambito degli schemi di Certificazione di Prodotto per lermatizzati a lega con facili a circolazione forata e serramenti esterni"

PARTECIPAZIONI ASSOCIATIVE:

- AIA: Associazione Italiana di Acustica
- AICARRI: Associazione Italiana Condizionamento dell'Aria Residuale Refrigerazione
- AIO: Associazione Italiana per la Qualità
- AIPID: Associazione Italiana Prove non Distruttive
- ALP: Associazione Laboratori Italiani Fusi
- ALPI: Associazione Laboratori di Prova, Indipendenti
- ASHRAE: American Society of Heating, Refrigerating and Air-Conditioning Engineers Inc.
- ASSINDUSTRIA: Associazione degli Industriali di Rimini
- ASTM: American Society for Testing and Materials
- ATG: Associazione Tecnica Italiana dei Gas
- CCI: Collegio dei Geometri della Industrializzazione Edifica
- CCI: Comitato Tecnico Italiano
- EARMA: European Association of Research Managers and Administrators
- EARTO: European Association of Research and Technology Organization
- EGOLF: European Group of Offices Laboratories for Fire Testing
- UNI: Ente Nazionale Italiano di Unificazione

CLAUSOLE

Il presente documento è riferito solamente ai campioni e materiale sottoposto a prova.
"Il presente documento non può essere riprodotto parzialmente, salvo approvazione scritta del laboratorio"

ABRIDGED TEST REPORT No. 189470

(Refers to test report No. 189076 issued by this Institute on 26/10/2004)

Place and date of issue: Bellaria, 08/11/2004

Customer: AIGNEP S.p.A. - Via Industriale n. 1 - 25070 BIONE (BS)

Date test requested: 13/09/2004

Order number and date: 26665, 14/09/2004

Date specimen received: 13/09/2004

Date test effected: from 11/10/2004 to 15/10/2004

Purpose of test: Testing copper-alloy quick-action couplings for use with aluminium tubes

Test site: Istituto Giordano S.p.A. - Blocco 1 - Via Rossini, 2 - 47814 Bellaria (RN)

Specimen origin: supplied by Customer

Identification of specimen received: No. 2004/1522

Description of specimen

The test specimens are known as "Raccordi ad innesto rapido per tubazioni in alluminio Serie 90.000".

Result of test

The tests listed below, agreed with the Customer and, in the absence of specific standards, conducted in accordance with standard UNI EN 1254-2: 2000, gave the following results:

- Leaktightness under internal pneumatic pressure: No visible signs of leakage;
- bursting strength test: DN 20: 115 bar, DN 25: 75 bar, DN 32: 78 bar, DN 40: 75 bar, DN 50: 58 bar and DN 63: 62 bar;
- resistance to pull-out: maximum axial movement 0,9 mm and no visible leakage in the subsequent pneumatic pressure test;
- leaktightness under internal pneumatic pressure whilst subjected to bending: no visible signs of leakage or damage.

As regards the description of the specimen, normative references, test methods, test equipment, test results and everything else necessary for the identification of the work carried out, please see Test Report No. 189076 issued by this Institute on 26/10/2004.



Test Technician
(Per. Ind. Walter Frattini)



Manager, Applied Physics
Laboratory
Dott. Ing. Vincenzo Iommi



Chairman or
Managing Director
Dott. Ing. Vincenzo Iommi



Comp. AV
Reviso 

This abridged report consists of 1 sheet
This document is the English translation of the abridged test report No. 189470 of 08/11/2004 issued in Italian.
Date of translation: 29/11/2004.

Sheet
1 of 1



Istituto Giordano S.p.A.
 Via Rossini, 2 - 47814 Bellaria-Igea Marina (RN) - Italia
 Tel. +39 0541 343030 - Fax +39 0541 345540
 istitutogiordano@giordano.it - www.giordano.it
 PEC: ist-giordano@legalmail.it
 Cod. Fisc./Part. IVA: 00 549 540 409 - Cap. Soc. € 1.500.000 i.v.
 R.E.A. c/o C.C.I.A.A. (RN) 156766
 Registro Imprese di Rimini n. 00 549 540 409

ABRIDGED TEST REPORT No. 317262

(Refers to test report No. 316851 issued by Istituto Giordano on 25/06/2014)

Place and date of issue: Bellaria-Igea Marina - Italy, 11/07/2014
Customer: AIGNEP S.p.A. - Via Don Giuseppe Bazzoli, 34 - 25070 BIONE (BS) - Italy
Date test requested: 20/03/2014
Order number and date: 62619, 24/03/2014
Date sample received: 23/04/2014
Test date: from 05/06/2014 to 24/06/2014
Purpose of test: testing aluminium-alloy quick-action couplings for use with aluminium tubes
Test site: Istituto Giordano S.p.A. - Blocco 1 - Via Rossini, 2 - 47814 Bellaria-Igea Marina (RN) - Italy
Sample origin: sampled and supplied by the Customer
Identification of sample received: No. 2014/0843

Sample name and description*

The test samples are called "Series 90.000, DN80 quick-action couplings for use with aluminium tubes".

They essentially consist of:

- surface-treated aluminium nut;
- NBR O-ring;
- surface-treated aluminium body;
- safety ring made from engineering resin;
- AISI 301 stainless-steel collet;
- tube guide ring made from engineering resin;
- galvanised-steel self-locking nut;
- galvanised-steel hexagon socket head cap screw.

Customer's declared maximum operating pressure is 16 bar.

Test result

The following tests were carried out on the Customer-supplied sample with results as given hereafter:

- leaktightness under internal pneumatic positive (24 and 0,5 bar)/negative (0,9 bar) pressure
TEST RESULT: PASS;
- bursting strength test
TEST RESULT: slight leakage from plug of one of the fittings at a pressure of 64 bar (PASS);
- resistance to pull-out
TEST RESULT: PASS;
- leaktightness under internal hydrostatic pressure whilst subjected to bending
TEST RESULT: PASS.

As regards sample and test photos, normative references, test methods, test equipment, detailed test results and everything else necessary for the identification of the work carried out, please see Test Report No. 316851 issued by Istituto Giordano on 25/06/2014.

(* according to that stated by the Customer.

Test Technician:
 Dott. Ing. Antonietta Serra

Head of Applied Physics Laboratory:
 Dott. Ing. Vincenzo Iommi

Chief Executive Officer
 (Dott. Arch. Sara Lorenza Giordano)



Firmato digitalmente da SARA LORENZA GIORDANO

The original of this document consists of an electronic document with a digital signature affixed pursuant to DPR (Presidential Decree) 513/97.

Comp. AV
 Revis. AS

This abridged report consists of 1 sheets.
 This document is the English translation of the abridged report No. 317262 dated 11/07/2014 issued in Italian; in case of dispute the only valid version is the Italian one. Date of translation: 06/06/2017.

Sheet
 1 of 1

CLAUSES: This document relates only to the sample or material tested and shall not be reproduced except in full without Istituto Giordano's written approval.



Istituto Giordano S.p.A.
Via Rossini, 2 - 47814 Bellaria (RN) Italy
Tel. +39 0541 343030 - Fax +39 0541 345540
istitutogiordano@giordano.it - www.giordano.it
Cod. Fisc./P.Iva 00 549 540 409 - Cap. Soc. € 880.000 i.v.
R.E.A. d/o C.C.I.A.A. (RN) 156766
Registro Imprese di Rimini n. 00 549 540 409
Organismo Europeo notificato n. 0407
Accreditamenti: SINCERT (057A e 082B) - SIT (20)

RICONOSCIMENTI UFFICIALI MINISTERI ITALIANI:

- Legge 1086/71 con D.M. 27/11/82 n. 22913 "Prove sui materiali da costruzione".
- D.M. 05/11/96 "Certificazione CE per le unità da diporto".
- D.M. 04/06/94 "Certificazione CEE sulle macchine".
- Notifica n. 73790 del 15/10/96 "Certificazione CEE per gli apparecchi a gas".
- D.M. 06/07/92 "Certificazione CEE in materia di recipienti semplici a pressione".
- D.M. 06/07/93 "Certificazione CEE concernente la sicurezza dei giocattoli".
- Incarichi di verifica della sicurezza e conformità dei prodotti nell'ambito della sorveglianza sul mercato e tutela del consumatore.
- D.M. 02/04/88 "Rilascio di attestazioni di conformità delle caratteristiche e prestazioni energetiche dei componenti degli edifici e degli impianti".
- Legge 81/84 e D.M. 26/03/85 con autorizzazione del 21/03/86 "Prove di resistenza al fuoco secondo D.M. 26/03/84".
- Legge 81/84 e D.M. 26/03/85 con autorizzazione del 10/07/86 "Prove di resistenza al fuoco secondo Circolare n. 91 del 14/09/81".
- Legge 81/84 e D.M. 26/03/85 con autorizzazione del 03/07/82 "Prove di resistenza al fuoco secondo Circolare n. 7 del 02/04/81 norma CNV/VI/CCI UNI 9723".
- Legge 81/84 e D.M. 26/03/85 con autorizzazione del 12/04/88 "Prove su estrattori d'incendio portatili secondo D.M. 29/12/82".
- Legge 45/82 con D.M. 06/10/85 "Inmissione nell'elenco dei laboratori autorizzati a svolgere ricerche di carattere applicativo a favore delle piccole e medie industrie".
- Protocollo n. 718 del 27/03/87 "Ispezione allo Scadenzario Anagrafe Nazionale delle Ricerche con codice N.0480797".
- Decreto 24/05/82 "Certificazione CE di rispondenza della conformità delle attrezzature a pressione".
- Decreto 14/02/82 "Certificazione CE di conformità in materia di emissione acustica ambientale per macchine e attrezzature".
- Decreto 05/02/83 "Esecuzione delle procedure di valutazione della conformità dell'equipaggiamento marittimo".
- G.U.R.I. n. 236 del 07/10/84 "Certificazione CE sugli ascensori".
- Notifica per le attività di attestazione della conformità alle norme armonizzate della Direttiva 89/105 sui prodotti da costruzione.

ENTI TERZI:

- SINCERT: Accreditamenti n. 057A del 19/10/00 "Organismo di certificazione di sistemi di gestione per la qualità" n. 082B del 12/04/06 "Organismo di certificazione di prodotto".
- SIT: Centro multisede n. 20 (Bellaria - Ponente) per prove termomeccaniche ed elettriche.
- ICM: "Prove di laboratorio nell'ambito degli schemi di Certificazione di Prodotto".
- IMQ: "Prove di laboratorio nell'ambito degli schemi di Certificazione di Prodotto per cune fusibili".
- UNCSAAL: Riconoscimento del 26/03/85 "Laboratorio per le prove di certificazione UNCSAAL su serramenti a facciate continue".
- IMO UNI: "Prove di laboratorio nell'ambito degli schemi di Certificazione di Prodotto per termocammetti a legna con fluido a circolazione forzata".
- CSI-UNI: "Prove di laboratorio in ambito degli schemi di Certificazione di Prodotto per serramenti esterni".
- KEMMANS per isolati termici: "Misure di conduttività termica per materiali isolanti".
- FT: "Prove di laboratorio e sorveglianza in azienda nell'ambito degli schemi di Certificazione di Prodotto per porte, finestre, chiusure oscuranti (antidive) e serramenti".
- EFGS: "Prove di laboratorio su caseolari e altri pezzi di custodia".
- AENOR: "Valutazione della conformità ai fini della marcatura CE per alcuni prodotti inerenti la direttiva prodotti da costruzione".
- VTI-Festind: "Valutazione della conformità ai fini della marcatura CE per alcuni prodotti inerenti la direttiva prodotti da costruzione".
- C.C.I.A.A. Rimini 26/01/04 "Verifica periodica dell'attendibilità metrologica di strumenti metrologici in materia di commercio".

PARTECIPAZIONI ASSOCIATIVE:

- AIA: Associazione Italiana di Acustica.
- AICARR: Associazione Italiana Condizionamento dell'Aria Riscaldamento Refrigerazione.
- AIDQ: Associazione Italiana per la Qualità.
- AIPrD: Associazione Italiana Prove non Distruttive.
- ALF: Associazione Laboratori Italiani Fuoco.
- ALP: Associazione Laboratori di Prova Indipendenti.
- ASHRAE: American Society of Heating, Refrigerating and Air-Conditioning Engineers Inc.
- ASTM: American Society for Testing and Materials.
- ATIG: Associazione Tecnica Italiana del Gas.
- CTE: Collegio dei Tecnici della Industrializzazione Edilizia.
- CTI: Comitato Termotecnico Italiano.
- EARMA: European Association of Research Managers and Administrators.
- EARTO: European Association of Research and Technology Organisation.
- EGOLF: European Group of Official Laboratories for Fire Testing.
- UNI: Ente Nazionale Italiano di Unificazione.

CLAUSOLE:

Il presente documento si riferisce solamente al campione e materiale sottoposto a prova.
Il presente documento non può essere riprodotto parzialmente, salvo approvazione scritta del laboratorio.

ABRIDGED TEST REPORT No. 238763
(Refers to test report No. 236272 issued by this Institute on 07/02/2008)

Place and date of issue: Bellaria-Igea Marina - Italy, 07/04/2008
Customer: AIGNEP S.p.A. - Via Industriale, 1 - 25070 BIONE (BS) - Italy
Date test requested: 09/11/2007
Order number and date: 39092, 09/11/2007
Date specimen received: 20/11/2007
Date test effected: from 20/12/2007 to 08/01/2008
Purpose of test: Testing copper-alloy quick-action couplings for use with aluminium tubes
Test site: Istituto Giordano S.p.A. - Blocco 1 - Via Rossini, 2 - 47814 Bellaria-Igea Marina (RN) - Italy
Specimen origin: sampled and supplied by Customer
Identification of specimen received: No. 2007/2505

Description of specimen

The test specimens are known as "Raccordi ad innesto rapido per tubazioni in alluminio Serie 90.000" ("Copper-alloy quick-action couplings for use with aluminium tubes Series 90.000"), DN 110.

Result of test

The tests listed below, agreed with the Customer and, in the absence of specific standards, conducted in accordance with standard UNI EN 1254-2:2000, gave the following results:

- leaktightness under internal pneumatic pressure: No visible signs of leakage;
- bursting strength test: 51 bar;
- resistance to pull-out: maximum axial movement 0,49 mm and no visible leakage in the subsequent pneumatic pressure test;
- leaktightness under internal hydraulic pressure whilst subjected to bending: no visible signs of leakage or damage.

As regards the description of the specimen, normative references, test methods, test equipment, test results and everything else necessary for the identification of the work carried out, please see Test Report No. 236272 issued by this Institute on 07/02/2008.

Test Technician (Per. Ind. Walter Fratto) Manager, Applied Physics Laboratory (Dott. Ing. Vincenzo Iommi) Chairman or Managing Director (Dott. Ing. Vincenzo Iommi)

Comp. AV
Revis:

This abridged report consists of 1 sheet
This document is the English translation of the abridged test report No. 238763 of 07/04/2008 issued in Italian.
Date of translation: 07/04/2008.

Sheet
1 of 1

RISULTATI ESTRATTI DAL RAPPORTO DI PROVA N° 189076, N° 236272 E N° 312056 DELL' ISTITUTO GIORDANO

OUTCOME OF THE TEST NR. 189076, NR. 236272 AND N° 312056 OF GIORDANO INSTITUTE

AUSZÜGE VON TESTERGEBNISSEN NR.° 189076, NR.° 236272 UND NR.° 312056 VOM INSTITUT GIORDANO

EXTRAITS DES RÉSULTATS DES TESTS NO189076, NO 236272 ET NO 312056 DE L'INSTITUT GIORDANO

Resultados de la prueba NR. NR.189076, NR. 236272 y N° 312056 de GIORDANO INSTITUTE

RESULTADOS EXTRAÍDOS DO RELATÓRIO DE TESTE N° 189076 E N° 236272 DO INSTITUTO GIORDANO

Test	IT
Verifica della tenuta sotto pressione a 1,5 volte la pressione max dichiarata.	
Test	GB
Test of pressure 1.5 time higher of the max declared.	
Test	DE
Prüfdruck um 1,5 Mal höher als der angegebene maximale Betriebsdruck.	
Test	FR
Contrôle d'étanchéité à une pression 1,5 fois supérieur de la pression nominale et à 0,5 bar.	
Test	ES
Prueba de presión 1.5 veces más elevadas del máximo declarado.	
Teste	PT
Teste de pressão 1,5 vez maior do que a pressão máxima declarada.	

DN	Verifica tenuta pneumatica a 22,5 bar (1,5 PN) per 15 min	Verifica tenuta pneumatica a 0,5 bar per 15 min
	Pneumatic resistance at 22,5 bar (1,5 PN) for 15 min Pneumatische Beständigkeit bei 22,5 bar (1,5 PN) für 15 Minuten Résistance pneumatique à 22,5 bar (1,5 PN) pour 15 minute Resistencia neumática a 22,5 bar (1,5 PN) por 15 min Resistência pneumática a 22,5 bar (1,5 PN) por 15 minutos	Pneumatic resistance at 0,5 bar for 15 minute Pneumatische Beständigkeit bei 0,5 bar für 15 Minuten Résistance pneumatique à 0,5 bar pour 15 minute Resistencia neumática a 0,5 bar por 15 min Resistência pneumática a 0,5 bar por 15 minutos
20	Nessuna perdita visibile No visible leakage Kein erkennbarer Verlust Aucune fuite No fugas visibles Nenhuma perda ou vazamento visível	
25		
32		
40		
50		
63		
80		
110		

Test	IT
Prove di trazione a carico costante secondo la Norma UNI-EN 1254-2:2000 punto 5.5.	
Test	GB
Constant tensile stress in accordance with Norma UNI-EN 1254-2:2000 point 5.5.	
Test	DE
Zugversuche nach konstanter Belastung nach Norm: UNI-EN 1254-2:2000 Punkt 5.5.	
Test	FR
Essais de traction à charge constante selon la norme: UNI-EN 1254-2:2000 section 5.5.	
Test	ES
Prueba de tensión según norma UNI-EN 1254-2:2000 punto 5.5.	
Teste	PT
Testes de tração constante segundo a Norma UNI-EN 1254-2:2000 ponto 5.5.	

DN	Carico di trazione applicato	Sfilamento massimo del tubo dai raccordi	Verifica tenuta pneumatica a 6 bar
	Power of stress Angewendete Zugkraft Force de traction Potencia de tension Força aplicada (N)	Unthreading of tubes Extraktion des Rohres aus der Verschraubung Extraction du tube Tubos sin rosca Desconexão máxima entre conexões e tubo (mm)	Resistance at 6 bar Pneumatische Beständigkeit bei 6 bar Résistance à 6 bar Resistencia a 6 bar Verificação de vazamento pneumático a 6 bar
20	1500	0.9	Nessuna perdita visibile No visible leakage Kein erkennbarer Verlust Aucune fuite No fugas visibles Nenhuma perda ou vazamento visível
25	1500	0.4	
32	2000	0.4	
40	2000	0	
50	2000	0	
63	2500	0	
80	2500	0.3	
110	2500	0.49	

Test	IT
Verifica della pressione di scoppio.	
Test:	GB
Pressure of explosion.	
Test	DE
Überprüfen des Berstdruckes.	
Test	FR
Contrôle de la pression d'éclatement.	
Test	ES
Presión de explosión.	
Teste	PT
Teste de pressão de ruptura.	

DN	Pressione idraulica di rottura Hydraulic pressure of breaking Hydraulischer Berstdruck Pression hydraulique de d'éclatement Presión hidráulica de rotura Pressão hidráulica de ruptura
20	<p>Alla pressione di 115 bar si è avuto un parziale sfilamento del tubo da un raccordo, con perdita di notevole entità. <i>Pressure 115 bar unthreading of a fitting from the tube with leakage.</i> <i>Bei einem Druck von 115 bar gab es einen teilweisen Auszug der Rohrverbindung, mit einer signifikanten Verlustmenge.</i> <i>A une pression de 115 bars, extraction partielle du tube et pertes notables.</i> <i>Presión 115 bar: el tubo comienza a salir de las conexiones con fugas.</i> <i>A uma pressão de 115 bar houve uma parcial desconexão do tubo com a conexão causando um vazamento ar perceptível.</i></p>
25	<p>Alla pressione di 75 bar si è prodotto lo sfilamento totale del tubo da un raccordo. <i>Complete unthreading pressure 75 bar of a tube.</i> <i>Bei einem Druck von 75 bar erfolgt die Trennung zwischen Rohr und Verschraubung.</i> <i>Déconnexion du tube à une pression de 75 bar.</i> <i>Presión 75 bar: el tubo sale completamente de las conexiones.</i> <i>A uma pressão de 75 bar houve uma desconexão total do tubo com a conexão.</i></p>
32	<p>Alla pressione di 78 bar è iniziato lo sfilamento del tubo da un raccordo, con tenuta idraulica: a 93 bar si è prodotto lo sfilamento completo. <i>At 78 bar unthreading of a tube with wet seal; at 93 bar total unthreading.</i> <i>Bei einem Druck von 78 bar entstand eine teilweise Extraktion der Rohrverbindung, bei 93 bar eine komplette Trennung</i> <i>Extraction partielle du tube du raccord à 78 bar, déconnexion à 93 bar.</i> <i>Presión 78 bar: el tubo sale de las conexiones con juntas mojadas. 93 bar desconexión total.</i> <i>A uma pressão de 78 bar iniciou-se a desconexão do tubo com uma das conexões estanques; a 93 bar ocorreu total desconexão do tubo.</i></p>
40	<p>Alla pressione di 75 bar il tubo ha iniziato a sfilarsi da un raccordo: mentre si cercava di mantenere/innalzare il valore della pressione, si è prodotto lo sfilamento totale del tubo dal raccordo. <i>At 75 bar the tube becomes unthreaded while trying to increase the pressure.</i> <i>Vorzeitige Extraktion der Rohrverbindung bei 75 bar und grosse Verluste.</i> <i>Début d'extraction du tube du raccord à 75 bar et pertes notables.</i> <i>Presión 75 bar: el tubo comienza a salir de las conexiones con fugas.</i> <i>A uma pressão de 75 bar o tubo começou a se desconectar da conexão enquanto a pressão estava sendo incrementada.</i></p>
50	<p>Alla pressione di 58 bar il tubo ha iniziato a sfilarsi da un raccordo: lo sfilamento progressivo e la successiva perdita non hanno permesso di innalzare ulteriormente la pressione. <i>At 58 bar the tube has become unthreaded.</i> <i>Vorzeitige Extraktion der Rohrverbindung bei 58 bar und grosse Verluste, daher keine Anhebung des Druckes möglich</i> <i>Début d'extraction du tube du raccord à 58 bar et pertes notables.</i> <i>Presión 58 bar: el tubo sale completamente de las conexiones</i> <i>A uma pressão de 58 bar o tubo começou a se desconectar de uma das conexões</i> <i>a desconexão progressiva e as perdas não permitiram aumentar mais a pressão.</i></p>
63	<p>Alla pressione di 58 bar il tubo ha iniziato a sfilarsi da un raccordo: lo sfilamento progressivo e la successiva perdita non hanno permesso di innalzare ulteriormente la pressione. <i>At 58 bar the tube has become unthreaded.</i> <i>Vorzeitige Extraktion der Rohrverbindung bei 58 bar und grosse Verluste, daher keine Anhebung des Druckes möglich.</i> <i>Début d'extraction du tube du raccord à 58 bar et pertes notables.</i> <i>A uma pressão de 58 bar o tubo começou a se desconectar de uma das conexões.</i> <i>A uma pressão de 58 bar o tubo começou a se desconectar de uma das conexões:</i> <i>a desconexão progressiva e as perdas não permitiram aumentar mais a pressão.</i></p>
80	<p>Alla pressione di 64 bar si è manifestata una perdita. <i>At 64 bar, leakage.</i> <i>Bei 64 bar Leckagen, keine Möglichkeit den Druck zu erhöhen.</i> <i>A 64 bar, pertes empêchant de poursuivre le test.</i> <i>Presión 64 bar: fugas.</i> <i>A uma pressão de 64 bar foi verificado um vazamento.</i></p>
110	<p>Alla pressione di 36 bar si è manifestata una perdita. <i>At 36 bar, leakage.</i> <i>Bei 36 bar Leckagen, keine Möglichkeit den Druck zu erhöhen.</i> <i>A 36 bar, pertes empêchant de poursuivre le test.</i> <i>Presión 36 bar: fugas.</i> <i>A uma pressão de 36 bar foi verificado um vazamento.</i></p>

Test	IT
Verifica della tenuta sotto pressione pneumatica interna e contemporanea applicazione di sollecitazione a flessione, come Norma UNI-EN 1254-2:2000 punto 5.6.	
Test	GB
Resistance under pneumatic internal pressure and bending stress at the same time according to Norma UNI-EN 1254-2:2000 point 5.6.	
Test	DE
Prüfen der Dichtheit unter gleichzeitiger Anwendung von Biegespannung nach Norm: UNI-EN 1254-2:2000 Punkt 5.6.	
Test	FR
Contrôle d'étanchéité sous contraintes de flexion selon la norme : UNI-EN 1254-2:2000 section 5.6	
Test	ES
Resistencia bajo presión neumática interna y carga de flexión al mismo tiempo según norma UNI-EN 1254-2:2000 punto 5.6. Distancia entre puntos de flexión.	
Teste	PT
Resistência sob pressão pneumática interna e flexão da tubulação de acordo com a Norma UNI-EN 1254-2:2000 ponto 5.6.	

DN	Distanza tra i centri dei supporti applicato <i>Distance between bearing points Der Abstand zwischen den Stützpunkten Distance entre les points d'appuis Distancia entre puntos de flexion Distância entre os centros dos suportes montados</i>	Pressione pneumatica interna di prova <i>Pneumatic pressure Pneumatischer Prüfdruck Pression pneumatique Presión neumática Pressão pneumática interna de teste</i>	Verifica resistenza meccanica e tenuta pneumatica <i>Resistance and pneumatic stamina Prüfen der mechanischen Festigkeit und Dichtheit Résistance et endurance pneumatique Resistencia neumática y física Verificação da resistência mecânica e vedação contra vazamento</i>
	(mm)	(bar)	
20	1800	10	Nessuna perdita visibile <i>No visible leakage Kein erkennbarer Verlust Aucune fuite No fugas visibles Nenhuma perda ou vazamento visível</i>
25	1800	10	
32	1800	10	
40	2400	10	
50	2700	10	
63	3000	6	
80	3000	6	
110	3000	6	

Il certificato che riporta tutti i dettagli e modalità delle prove può essere richiesto.

*The certificate is available upon request.
Der vollständige Bericht ist auf Anfrage erhältlich.
Le rapport complet est disponible sur demande.
El certificado está disponible bajo demanda.
O certificado está disponível a pedido.*

DICHIARAZIONE DI CONFORMITA' PER GLI IMPIANTI DI DISTRIBUZIONE DELL'ARIA

CONFORMITY DECLARATION FOR THE DISTRIBUTION OF COMPRESSED-AIR
 KONFORMITÄTSERKLÄRUNG FÜR DIE DRUCKLUFTVERTEILUNG
 DÉCLARATION DE CONFORMITÉ - DISTRIBUTION D'AIR COMPRIMÉ
 DECLARACIÓN DE CONFORMIDAD PARA REDES DE AIRE COMPRIMIDO
 DECLARAÇÃO DE CONFORMIDADE PARA REDE DE DISTRIBUIÇÃO DE AR COMPRIMIDO

IT

Dichiaro che il sistema di distribuzione dell'aria alle seguenti condizioni di utilizzo:

- pressione -0,99÷16 bar
- temperatura -20°C÷ 80 °C

soddisfa la direttiva **2014/68/UE** (PED: Pressure Equipment Directive)

GB

We declare that the system used with pressure 0.99÷16 bar and temperature -20°C÷ 80 °C with directive **2014/68/UE (PED: Pressure Equipment Directive)**.

DE

Wir bestätigen, dass das Luftverteilungssystem zu den folgenden Nutzungsbedingungen:
 Druck -0,99 bis 16 bar / Temperatur -20°C bis 80 °C die Richtlinie **2014/68/UE (PED: Pressure Equipment Directive / Druckgeräterichtlinie)** erfüllt.

FR

Nous déclarons que le système utilisé entre -0,99 et 16 bar de pression, dans une plage de température de -20°C à 80°C répond à la Directive **2014/68/UE (directive des équipements sous pression)**.

ES

Declaro que el sistema utilizado a presión 0.99÷16 bar y temperatura -20°C÷ 80 °C es conforme a la Directiva **2014/68/UE (PED: Pressure Equipment Directive)**.

PT

Declaro que o sistema de redes de distribuição de ar comprimido, utilizado nas seguintes condições de trabalho: pressão -0,99 ~ 15 bar e temperatura -20°C ~ 80 °C satisfaz a diretiva **2014/68/UE (PED: Pressure Equipment Directive)**.

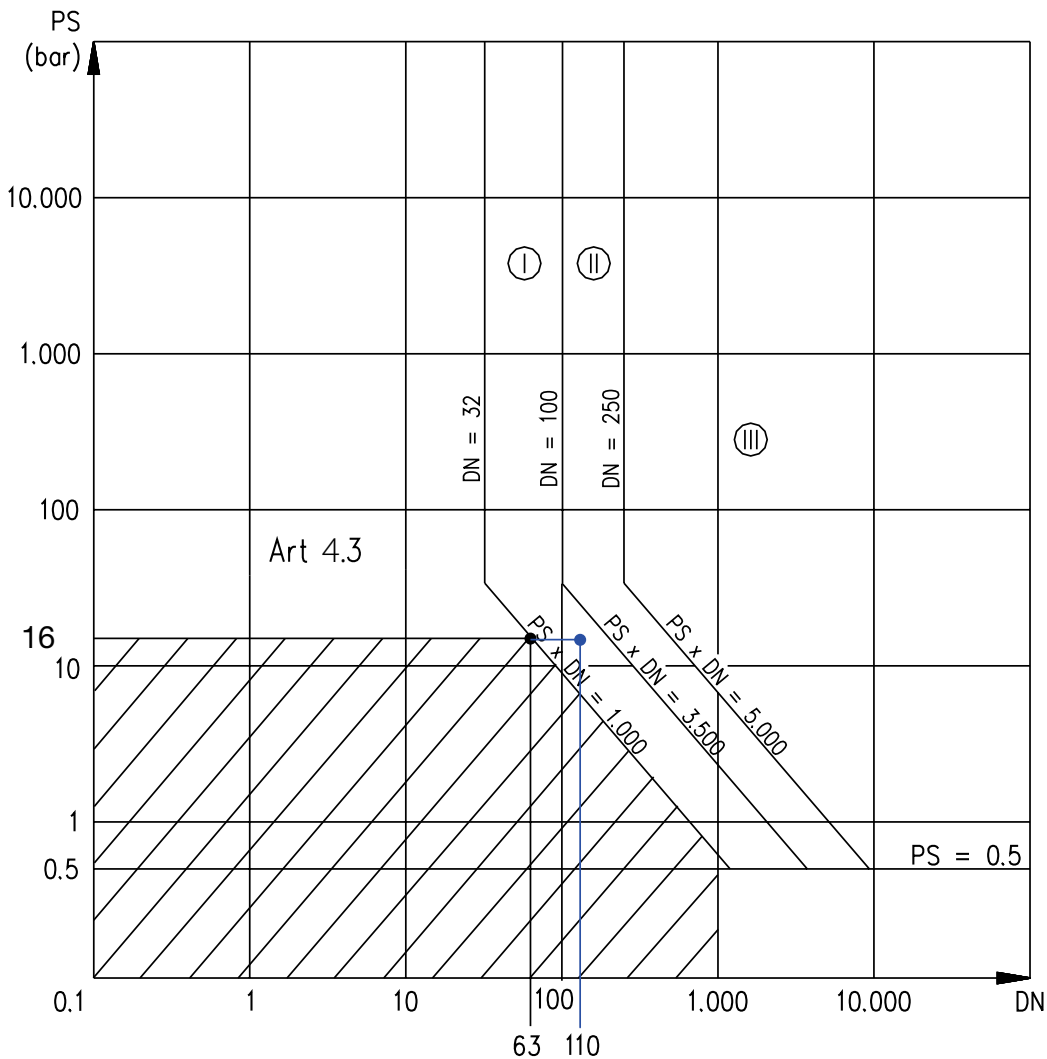

IT

Prendendo in considerazione il diametro interno per DN63 e la pressione massima di 16 bar, si osserva nel grafico, che il punto di intersezione PS x DN=16x59= 944 è alla sinistra della zona PS x DN= 1.000: zona esente dalla marcatura CE secondo la direttiva menzionata (Art.4 .3).

Quindi in base alla direttiva 2014/68/UE Art. 4.3 per tutti i tubi e i relativi raccordi (Ø20-Ø25-Ø32-Ø40-Ø50- Ø63) che costituiscono gli impianti di distribuzione dell'aria Infinity non è necessaria la marcatura CE. Prendendo in considerazione il diametro interno per DN 80, DN110 e la pressione massima di 16 bar, si osserva nel grafico, che il punto d'intersezione (PS X DN = 16x76 = 1216 per DN80) e (PS X DN = 16x105 = 1680 per DN 110) è nella zona individuata come categoria I.

In base alla direttiva 2014/68/UE per tale zona si prevede la valutazione della conformità secondo un controllo di fabbricazione interno.

GB

Considering the internal diameter for DN63 and max pressure 16 bar, on can see on the graphic that the intersection point PS x DN=16x59= 944 is on the left side of zone PS x DN= 1.000: it meas is exempt from CEE marking according to the above mantioned directive (Art.4.3). Therefore all tubes and fitting (Ø20-Ø25-Ø32-Ø40-Ø50- Ø63) do not require any CEE marking.

Considering the internal diameter for DN80, DN110 and maximum pressure of 16 bar, the intersection point (PS X DN = 16x76 = 1216 for DN80) and (PS X DN = 16x105 = 1680 for DN 110) in the chart above, is in the area called "CATEGORIA I".

According to Directive 2014/68/UE this area has a conformity evaluation made at factory.

DE

Auf der Grafik kann man sehen, dass beim Durchmesser 63 und Maximaldruck von 16 bar der Schnittpunkt PS x DN=59x16= 944 auf der linken Seite der Zone PS x DN= 1.000 liegt: das bedeutet in der CEE-Kennzeichnung freien Zone, gemäss der oben genannten Richtlinie (Art.4.3).

Deshalb benötigt keines der Rohre oder der Verschraubungen (Ø20-Ø25-Ø32-Ø40-Ø50- Ø63) eine CEE-Markierung.

Was den Durchmesser 80 und 110 bei einem Maximaldruck von 16 bar betrifft, liegen die Schnittpunkte PS X DN = 76x16= 1216 und 105x16 = 1680 auf der obenstehenden Grafik in der "CATEGORIA I" genannten Zone. Gemäss der Richtlinie 2014/68/UE muss in diesem Bereich eine Konformitätsbewertung im Werk gemacht werden.

FR

Si nous considérons dans le graphique ci-dessus le diamètre interne du tube de Ø63 mm et la pression maximale de 16 bar, le point d'intersection PS x DN = 59x16 = 944 se situe sur le côté gauche de la zone PS x DN = 1.000. Par conséquent, tous les tubes et les raccords du système de distribution d'air Infinity (Ø20-Ø25-Ø32-Ø40-Ø50-Ø63) ne nécessitent pas de marquage CEE selon la directive 2014/68/UE (Art. 4.3).

Considérant les diamètres internes des tubes de Ø80 mm et Ø110 mm ainsi que la pression maximale de 16 bar, les points d'intersections PS x DN = 105x16 = 1680 et 76x16=1216 se situent dans le tableau ci-dessus dans la zone appelée "CATEGORIE I".

Pour cette catégorie, la directive 2014/68/UE prévoit une évaluation de la conformité, selon un contrôle interne.

ES

Considerando el diámetro interno DN63 y la presión máxima 16 bar, en el gráfico el punto de intersección PS x DN=16x59= 944 está en el lado izquierdo PS x DN= equivalente a artículos exentos d "Marca CE" según norma indicada antes (Art. 4.3).

Por consiguiente tubos y conexiones (Ø20-Ø25-Ø32-Ø40-Ø50- Ø63) no necesitan la "Marca CE".

Considerando el diámetro interno DN80, DN110 y la presión máxima 16 bar, en el gráfico el punto de intersección (PS x DN=16x76= 1216 por DN80) y (PS X DN = 16x105 = 1680 for DN 110) está en el area "CATEGORIA I". Según norma 2014/68/UE esta area permite una evaluación de conformidad basada en controles a nivel de fábrica.

PT

Levando em consideração o diâmetro de 63mm e a pressão máxima de 15 bar, se observa no gráfico, que o ponto de intersecção PS x DN=63x15= 945 está à esquerda da zona PS x DN= 1.000: zona isenta de maração CE segundo a diretiva mencionada (Art.4.3).

Desta forma com base na diretiva 2014/68/UE Art. 4.3 para todos os tubos e conexões relacionadas (Ø20-Ø25-Ø32-Ø40-Ø50- Ø63) não é necessária a maração CE.

Levando em consideração o diâmetro 110mm e a pressão máxima de 15 bar, se observa no gráfico, que o ponto de intersecção PS X DN = 110x15 = 1650 está na zona chamada de "Categoria I".

Com base na diretiva 2014/68/UE para tal zona, é prevista uma verificação de conformidade executada através de um controle de fabricação executado na fábrica.

CONFORMITA' DEL PROCESSO DI VERNICIATURA A POLVERE POLIESTERE SU TUBI DI ALLUMINIO DELLA SERIE INFINITY

CONFORMITY OF POLYESTER POWDER PAINTING ON ALUMINIUM TUBES OF SERIE INFINITY
 KONFORMITÄT VON POLYESTER-PULVERBESCHICHTUNG AUF INFINITY-ALUMINIUMROHREN
 CONFORMITÉ DE LA PEINTURE POLYESTER DES TUBES EN ALUMINIUM DE LA SÉRIE INFINITY
 TUBOS ALUMINIO INFINITY REVESTIDOS CON PINTURA DE POLIÉSTER PULVERIZADA CONFORME.
 CONFORMIDADE DO PROCESSO DE PINTURA A PÓ (POLIÉSTER) NOS TUBOS DE ALUMÍNIO DA SÉRIE INFINITY

Pretrattamento IT	Pre-Treatment GB	Vorbehandlung DE
<p>Garantisce l'ancoraggio della vernice all'alluminio e ne previene la corrosione e l'ossidazione delle parti non verniciate. E' conforme alle seguenti normative tecniche: UNI 9921 - DIN 50939 - ASTM D 1730 - MIL C 5541</p> <hr/> <p>Verniciatura</p> <p>E' effettuata utilizzando vernice in polvere poliestere atossica certificata QUALICOT e GSB in conformità alle seguenti normative: UNI 9983 - BS 6496 - AAMA 603-605 I sopradescritti trattamenti rendono inattaccabile alla corrosione in ambienti marini la parte esterna dei tubi, in quanto completamente ricoperta di vernice. La parte interna solamente pretrattata (cromatata) offre comunque una discreta protezione.</p>	<p><i>It guarantees the anchorage of the painting to the tube and prevents corrosion and oxydation of not painted parts according to:</i> UNI 9921 - DIN 50939 - ASTM D 1730 - MIL C 5541</p> <hr/> <p>Painting</p> <p><i>Made using powder painting not-toxic certified QUALICOT and GSB according to:</i></p> <p>UNI 9983 - BS 6496 - AAMA 603-605</p> <p><i>The above mentioned treatments prevents corrosion to external part. Inside is treated with chrome.</i></p>	<p><i>Sie garantiert die Haftung der Farbe und verhindert Korrosion und Oxidation der lackierten Teile. Erfüllt folgende Normen:</i> UNI 9921 - DIN 50939 - ASTM D 1730 - MIL C 5541</p> <hr/> <p>Lackierung</p> <p><i>Unter Verwendung einer als ungiftig zertifizierten QUALICOT und GSB Polyester-Pulverbeschichtung, konform zu den folgenden Standards:</i></p> <p>UNI 9983 - BS 6496 - AAMA 603-605</p> <p><i>Die oben genannte Behandlung schützt die Aussenseite des Rohres vor Korrosion. Die Innenseite ist mit Chrom behandelt.</i></p>

Prétraitement FR	Pretratamiento ES	Pré-tratamento PT
<p><i>Il assure l'ancrage de la peinture et empêche la corrosion et l'oxydation des parties non peintes. Répond aux normes:</i> UNI 9921 - DIN 50939 - ASTM D 1730 - MIL C 5541</p> <hr/> <p>Peinture</p> <p><i>La peinture est fabriquée à l'aide de poudre polyester non toxique QUALICOT certifié Selon GSB:</i></p> <p>UNI 9983 - BS 6496 - AAMA 603-605</p> <p><i>Le traitement qui recouvre entièrement les tubes, les rend résistants à la corrosion dans des environnements marins. L'intérieur étant prétraité, celui-ci est protégé de manière optimale.</i></p>	<p><i>Garantiza la adherencia de la pintura y previene la corrosión o oxidación de partes sin cobertura, según</i> UNI 9921 - DIN 50939 - ASTM D 1730 - MIL C 5541</p> <hr/> <p>Pintura</p> <p><i>La pintura es en polvo no toxica, certificada QUALICOT y GSB según:</i></p> <p>UNI 9983 - BS 6496 - AAMA 603-605</p> <p><i>Esta pintura previene la corrosión de la parte exterior. Internamente es tratado con cromo.</i></p>	<p><i>Garante a fixação da tinta no alumínio e a também previne a corrosão e a oxidação das peças não pintadas garantindo a conformidade com as normas técnicas:</i> UNI 9921 - DIN 50939 - ASTM D 1730 - MIL C 5541</p> <hr/> <p>Pintura</p> <p><i>É executada utilizando tinta a pó de poliéster atóxica certificada QUALICOT e GSB em conformidade com as seguintes normativas:</i></p> <p>UNI 9983 - BS 6496 - AAMA 603-605</p> <p><i>Os tratamentos mencionados acima previnem a corrosão em ambientes marinhos na parte externa dos tubos, enquanto completamente recoberta pela pintura. A parte interna somente pré-tratada (com cromo) oferece também uma proteção aos tubos.</i></p>

CONFORMITA' ALLA TENUTA AL FUOCO

RESISTANCE TO FIRE
FEUERBESTÄNDIGKEIT
TENUE AU FEU
RESISTENCIA AL FUEGO
RESISTÊNCIA AO FOGO



Oggetto	IT	Subject	GB	Gegenstand	DE
Classificazione resistenza al fuoco di prodotti e componenti, sulla base dei risultati delle prove di reazione al fuoco secondo UNI EN 13501-1:2005.		Fire classification of construction products and building elements, based on the result of reaction to fire testing in accordance with UNI EN 13501-1:2005.		Die Feuerwiderstandsklassifizierung der Produkte und Komponenten, basiert auf den Testergebnissen zu Brandreaktionen, gemäss UNI EN 13501-1:2005.	
Descrizione prodotto		Description of the product		Produktbeschreibung	
Tubo di alluminio verniciato Serie 90000. La classificazione è determinata dall'analisi del calore di combustione della vernice in combinazione con i risultati dei test specificati in UNI EN ISO 13823 su lamine piatte equivalenti per spessore di alluminio e di vernice.		Painted aluminium pipe 90000 SERIES. Classification was determined by analysis of the paint's gross heat of combustion, coupled with test result as specified in UNI EN 13823 on equivalent flat sheets, having the same thickness of aluminium and paint as the pipe.		Lackiertes Aluminium-Rohr der Serie 90000. Die Klassifizierung wurde erstellt durch die Analyse der Verbrennungswärme der Farbe, in Kombination mit den UNI EN ISO 13823 spezifizierten Testergebnissen von flachen Aluminiumblechen in der gleichen Stärke und mit der gleichen Lackierung des Rohres.	
Risultato Test		Test Result		Testergebnis	
Il prodotto sottoposto al test è riconosciuto come prodotto di Classe A2 - d1 - d0 alla resistenza al fuoco.		The product under test has been awarded reaction to Fire Class A2 - d1 - d0, in accordance with test result obtained.		Das geprüfte Produkt wurde in der Feuerbeständigkeit als Produkt der Klasse A2 - d1 - d0 ausgezeichnet.	

Sujet	FR	Asunto	ES	Assunto	PT
Classification des produits à la résistance au feu sur la base des résultats des tests selon la norme EN 13501-1:2005.		Certificación del fuego para productos y componentes basado en ensayos de reacción al fuego según UNI EN 13501-1:2005		Classificação de resistência ao fogo dos produtos e componentes, com base nos resultados dos testes de reação ao fogo segundo UNI EN 13501-1:2005.	
Description des produits		Descripción del producto		Descrição do produto	
Tube en aluminium de la série 90000 La classification est déterminée par l'analyse de la chaleur de combustion des tubes en comparaison avec les résultats des essais spécifiés dans la norme UNI EN ISO 13823 sur des tôles d'aluminium peintes d'épaisseurs équivalentes.		Tubos Aluminio Infinity "90000 serie" revestidos. La clasificación mediante análisis de calor de combustión de la pintura, además de resultados específicos UNI EN 13823 sobre láminas planas con el mismo espesor y pintura.		Tubo de alumínio pintado Série 90000 A classificação é determinada pela análise do calor de combustão da tinta em combinação com os resultados dos testes especificados na UNI EN ISO 13823 feitos em lâminas chatas de alumínio com espessura e pintura equivalentes às utilizadas nos tubos.	
Résultats		Resultados de la prueba		Resultado de Teste	
Le produit est attesté classe A2 - d1 - d0 en tenue au feu.		El producto ha sido premiado con el grado de resistencia "FIRE CLASS A2 - d1 - d0", según pruebas.		O produto submetido ao teste foi aprovado como produto de Classe A2 - d1 - d0 com relação a resistência ao fogo.	